

TC-558

USA Model
Canada Model
PX Model



STEREO TAPECORDER

SPECIFICATIONS

Power Requirements: 120 V ac, 50/60 Hz (USA, Canada Model)
120 V ac, (100, 110, 127, 220, 240 V ac adjustable by authorized Sony personnel), 50/60 Hz (PX Model)

Power Consumption: 70 W (MITI standards)
100 W (CSA, UL and IEC standards)

Track System: 4 tracks, 2 channel stereo or monaural

Reels: 178 mm (7 inches) or smaller

Tape Speeds: 19 cm/s (7½ ips), 9.5 cm/s (3¾ ips)

Frequency Response: NAB: (USA, Canada, PX Model)

tape speed	with normal tape	with SONY SLH tape
19 cm/s (7½ ips)	20~25,000 Hz 30~20,000 Hz (±3 dB)	20~30,000 Hz 30~25,000 Hz (±3 dB)
9.5 cm/s (3¾ ips)	20~17,000 Hz	20~20,000 Hz

DIN: (PX Model)

tape speed	with normal tape	with SONY SLH tape
19 cm/s (7½ ips)	30~20,000 Hz	30~25,000 Hz
9.5 cm/s (3¾ ips)	30~13,000 Hz	30~15,000 Hz

S/N Ratio: 56 dB (with SONY SLH tape)
53 dB (with normal tape)

Wow and Flutter: NAB: (USA, Canada, PX Model)
0.05% at 19 cm/s (7½ ips)
0.09% at 9.5 cm/s (3¾ ips)
WRMS
DIN: (PX Model)
±0.09% at 19 cm/s (7½ ips)
±0.12% at 9.5 cm/s (3¾ ips)

Harmonic Distortion: 1.2%

Inputs: MICROPHONE (phone jack) . . . 2
Sensitivity 0.2 mV (-72 dB)
Accept low impedance microphones.

LINE IN (phono jack) 2
Sensitivity 0.06 V (-22 dB)
Impedance 100 kΩ

REC/PB (DIN jack) . . (PX Model only)
Impedance lower than 10 kΩ

Outputs: LINE OUT (phono jack) 2
Output level 0.43 V (-5 dB) at load impedance of 100 kΩ, with PB LEVEL controls set to the center detent position (0.775 V = 0 dB . . . with PB LEVEL controls set to MAX.)
Suitable load impedance higher than 10 kΩ

REC/PB (DIN jack) . . (PX Model only)
Output level 0.775 V (0 dB) with PB LEVEL controls set to the center detent position
Impedance lower than 10 kΩ

HEADPHONE (stereo binaural jack) accepts 8 Ω stereo headphones.

Dimensions: 458 (w) x 425 (h) x 213 (d) mm
18 ½ (w) x 16 ¾ (h) x 8 ½ (d) inches including projecting parts and controls

Weight: 20.8 kg (45 lb 14 oz)

SONY®

SERVICE MANUAL

SECTION 1 OUTLINE

1-1. BLOCK DIAGRAM — Amp Section —

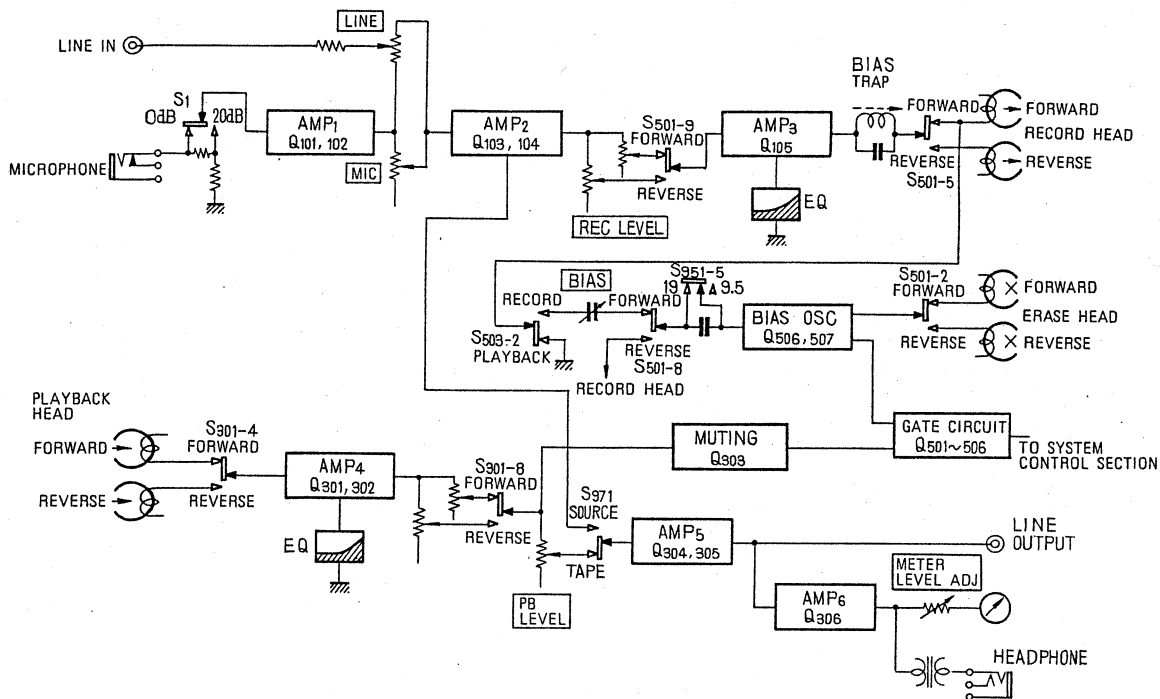

— System Control Section —

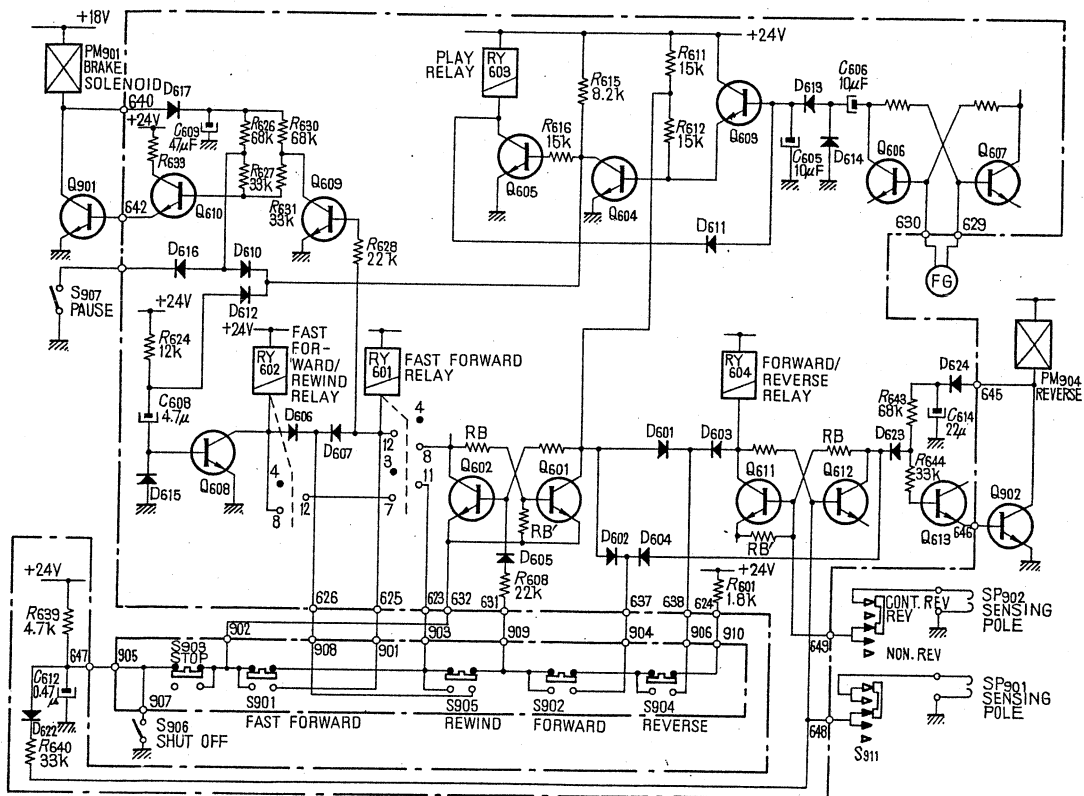

1-2. EXTERNAL VIEWS
- Top View -

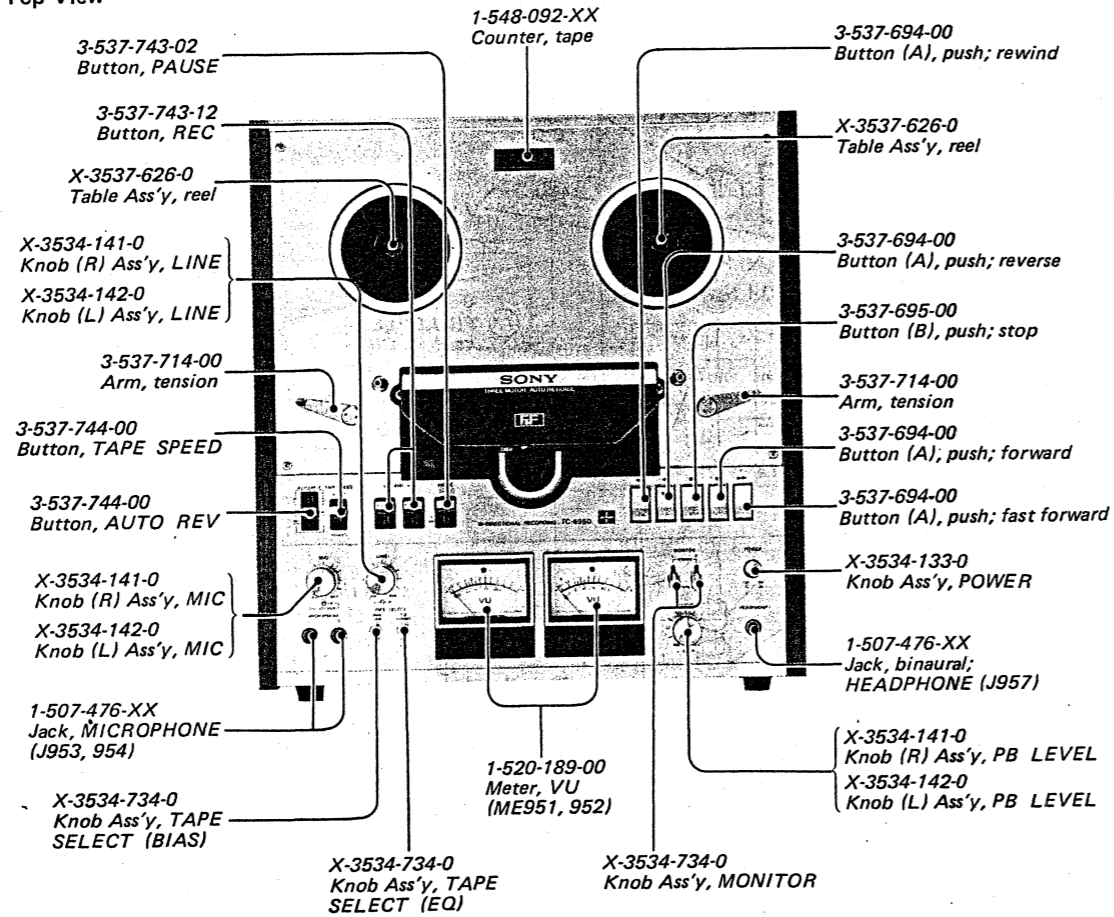

- Bottom View -

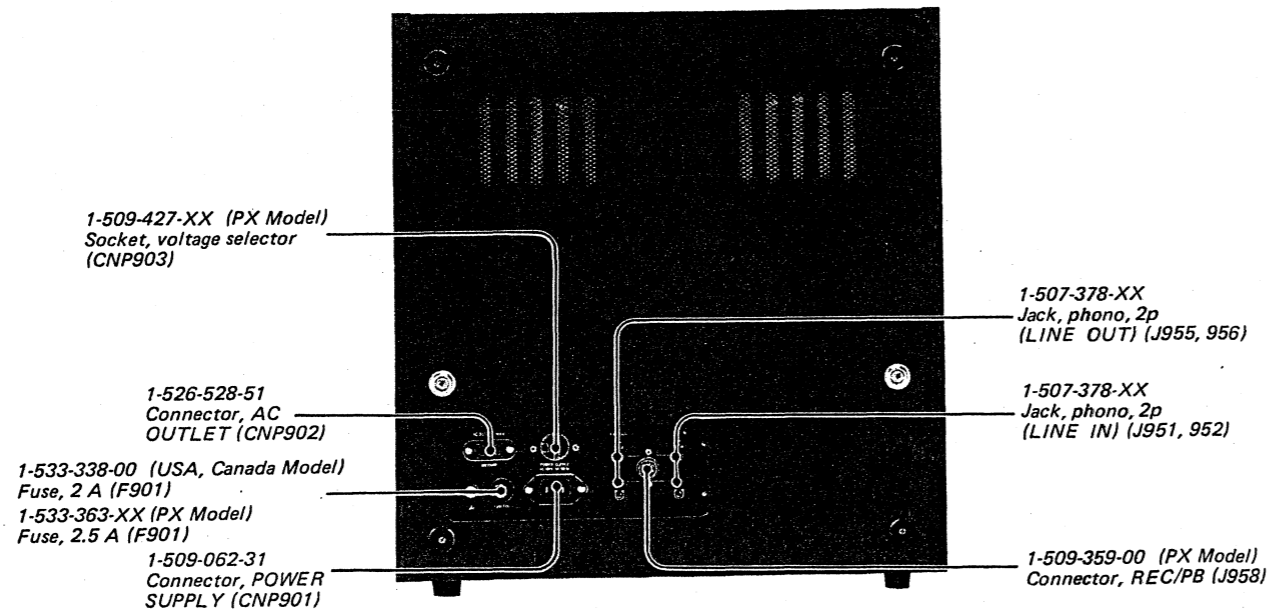

1-3. INTERNAL VIEWS
- Top View (1) -

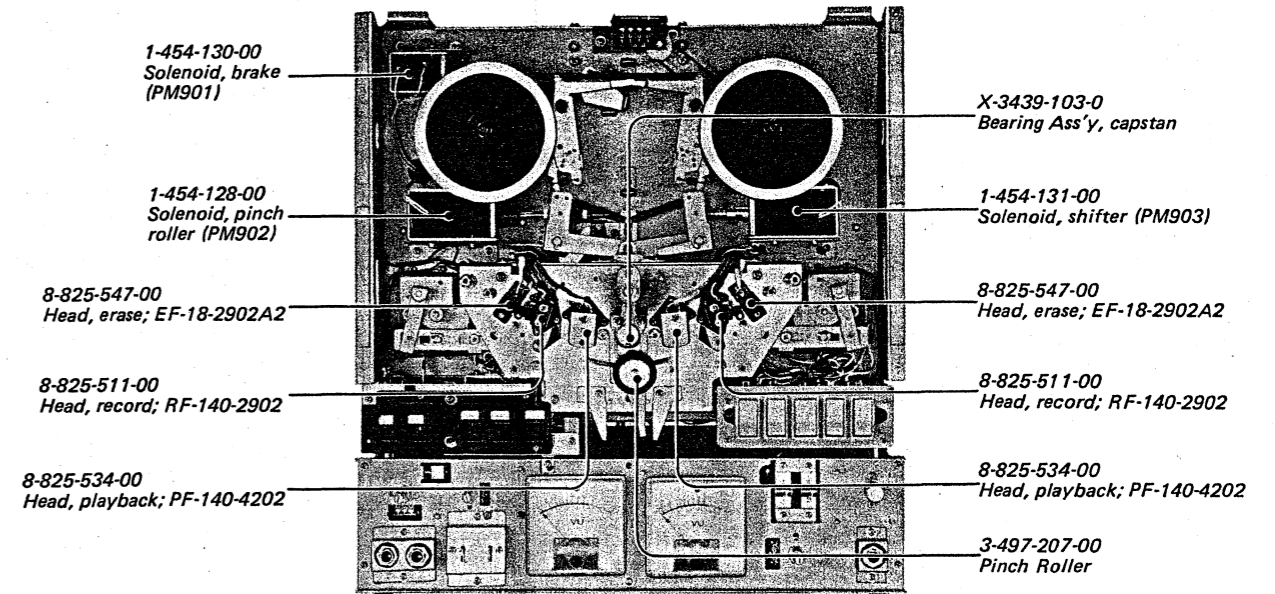

- Top View (2) -

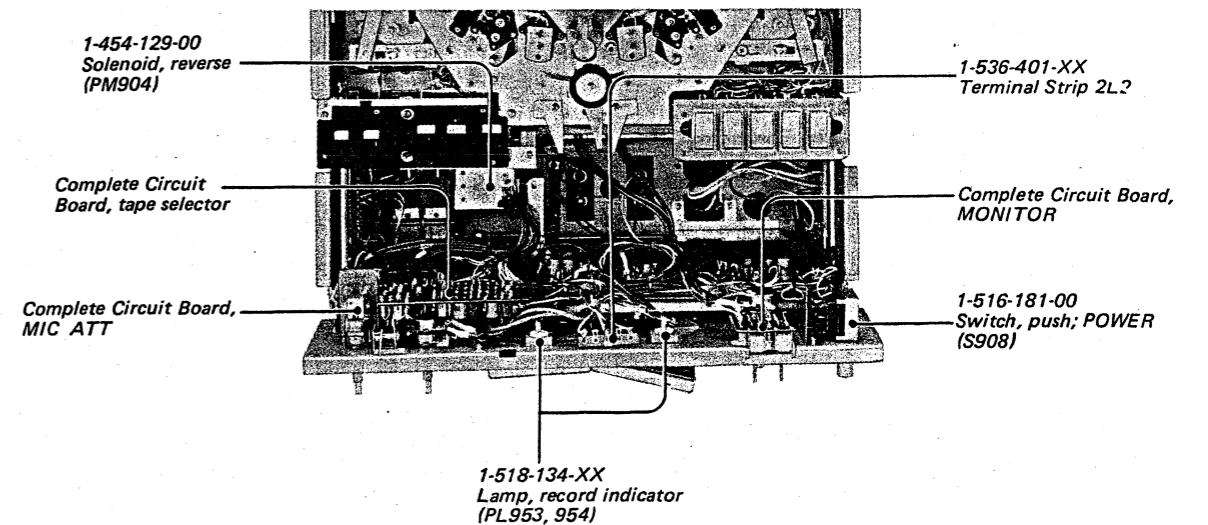

SECTION 2
DISASSEMBLY

— Side View —

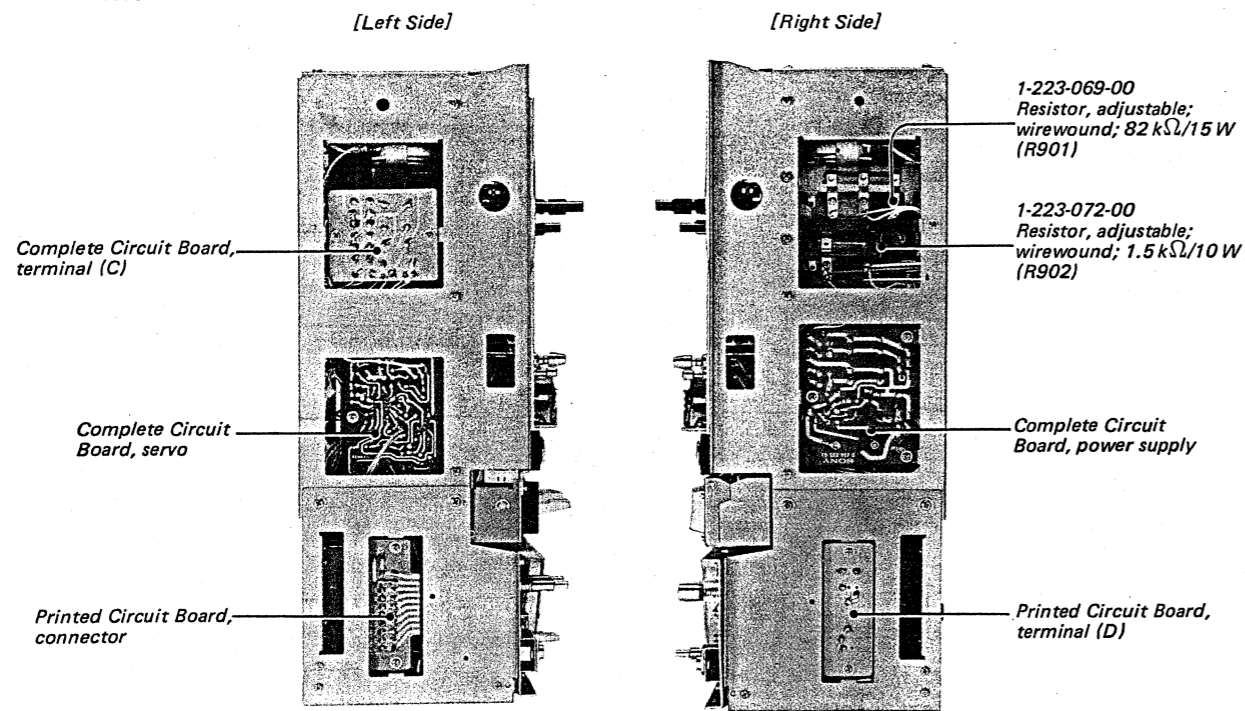

— Bottom View —

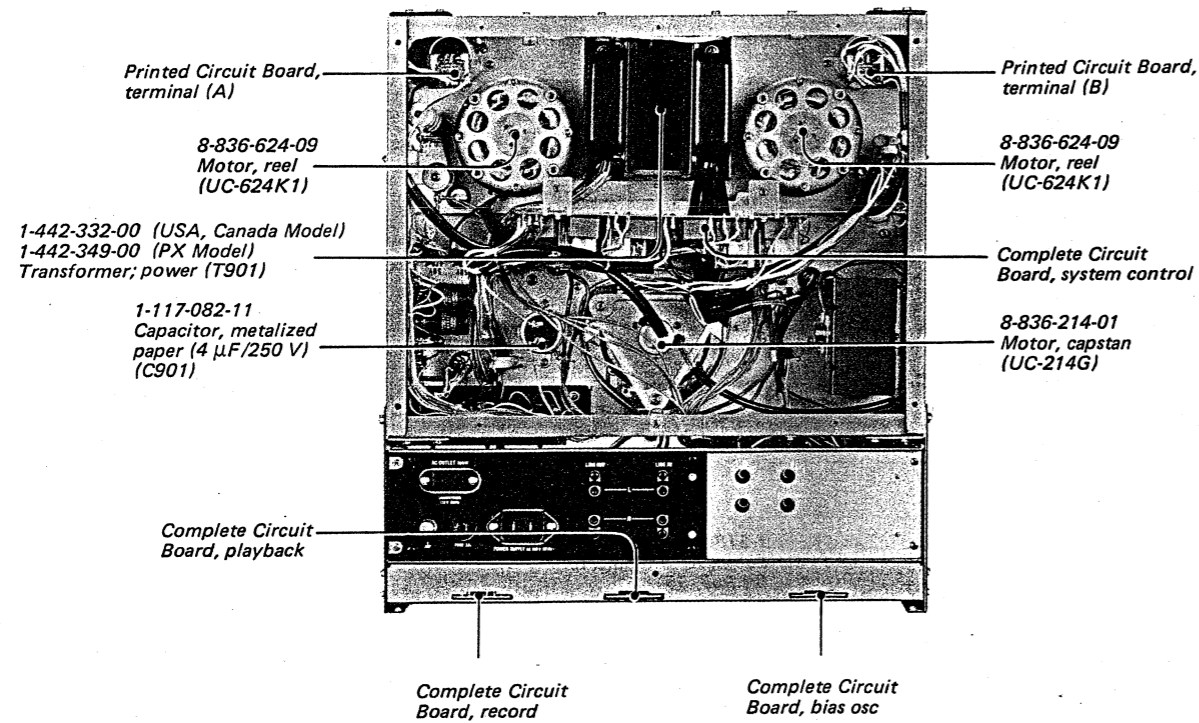

CABINET REMOVAL: ① ~ ⑩
AMP PANEL AND REEL PANEL REMOVAL: ⑪ ~ ⑲

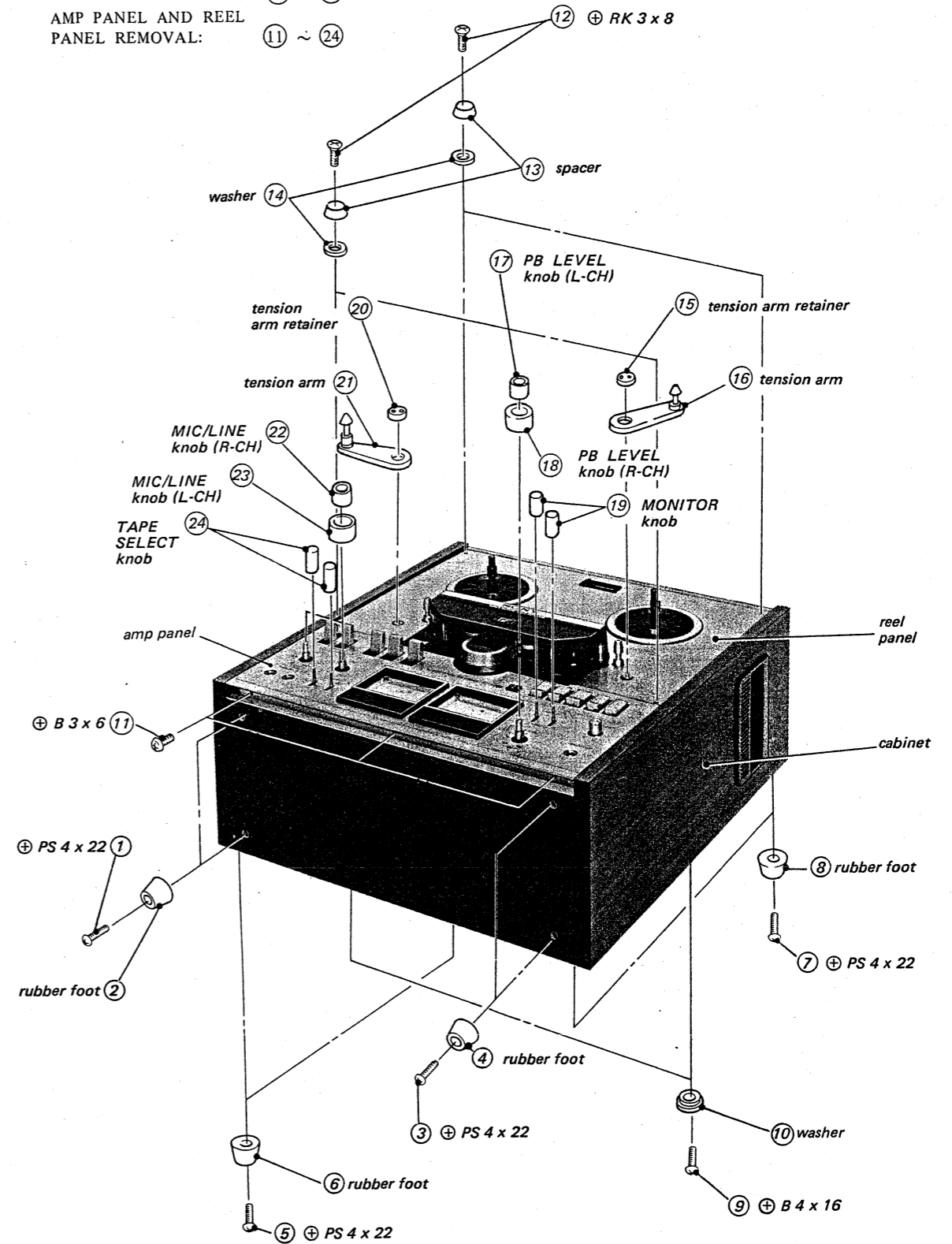

SECTION 3
ADJUSTMENTS

3-1. MECHANICAL ADJUSTMENTS

Brake Torque Adjustment
— stop mode —
Set the brake lever by moving the brake arm as shown.

Change the hooking position of the spring for the specified brake torque.

Specification:

Take-up Reel	Supply Reel	Brake Torque
clockwise	counter-clockwise	1000 ~ 1400 g·cm (13.9 ~ 19.5 oz·inch)
counter-clockwise	clockwise	300 ~ 400 g·cm (4.17 ~ 5.55 oz·inch)

Reel Table Height Adjustment

1. Thread a 7-inch tape.
2. Make sure that the tape does not touch the reel flanges in forward playback, reverse playback, fast forward and rewind modes.
3. If the tape touches the reel flanges, adjust the reel table height by loosening the two adjustment screws.

Pinch Roller Pressure Adjustment
— playback mode —

1. Hook the spring scale to the base of the pinch roller shaft.
2. Pull the spring scale in the counter direction of the capstan.
3. Allow the pinch roller to return slowly and measure the pressure (spring scale tension) at the point where the pinch roller just contacts the capstan.

Specification: 1,200 to 1,400 g·cm
(16.7 to 19.4 oz·inch)

4. If necessary, adjust by turning the adjustment nut (A).
5. Make sure of the clearance indicated by ★.
6. After completing the adjustment, apply locking compound to the nuts.

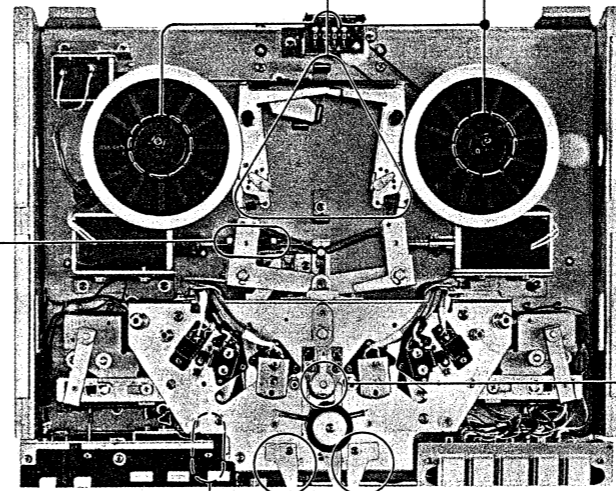

Capstan Shaft Position Adjustment
— forward or reverse playback mode —

Test Setup: — forward or reverse playback mode —

Procedures:

1. Loosen the two adjustment screws, and move the pinch roller bracket to left and right, front and back for maximum meter reading.
2. Tighten the adjustment screws.
3. After completing the adjustment, apply locking compound to the adjustment screws.

Pause Lever Adjustment
— forward or reverse playback mode —

1. With PAUSE button pulled, adjust pause lever position by loosening the two adjustment screws so that clearance between pinch roller and capstan is 1 mm (1/32").

Note: When the mode is changed from forward playback to reverse playback in PAUSE mode or vice versa, PAUSE button should not be released.

Direction Change Stopper Position Adjustment
— forward and reverse playback modes —

1. Loosen the screws and adjust the direction change stopper position for the clearance shown. Tighten the screws.
2. Make sure of each function in the following order:
forward playback → rewind → stop → reverse playback → stop → forward playback
3. If each function does not smoothly change, readjust by moving the direction change stopper.
4. Apply locking compound to the screws.

Tape Pass Adjustment

a). Tape Guide Adjustment

1. Thread the tape, and set the TAPE SPEED switch to "19 cm".
2. Make sure that the tape is correctly running in forward and reverse playback mode.
3. Make sure that the tape does not curl at the portions indicated by ★.

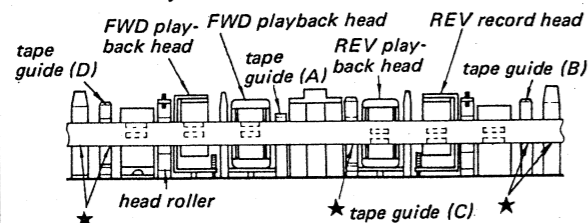

4. If necessary, adjust the tape guides (B), (C) and (D) relative to the tape guide (A).
5. Adjust the both tension arm heights by turning the adjustment screws.

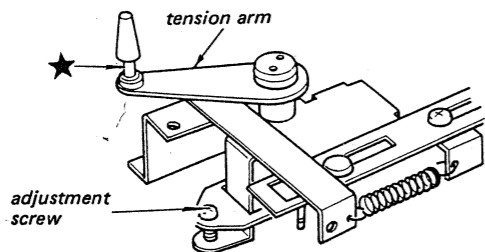

b). Pinch Roller Check

1. Thread a 7-inch tape, and set the TAPE SPEED switch to "19 cm".
2. Make sure that the beginning portion of tape is correctly running, and does not move up and down on the both tape guides near the pinch roller.

c). Head Roller Adjustment

1. Thread a 7-inch tape, and run the tape in forward and reverse playback mode.
2. Make sure that the head roller is rotating, and hold the head roller by fingers.
3. Make sure that the head roller starts rotating again, when taking off fingers from the head roller.
4. Make sure that the tape is not wavy at the head roller.
5. If necessary, adjust the angle of head roller by using the spacer as shown.

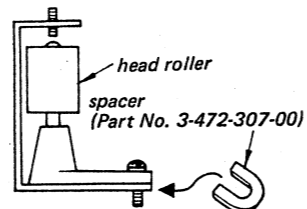

d). Adjustments after Playback and Record Head Replacement

Note: When replacement of both playback and record heads is required, leave one of them unremoved for the reference of adjustments. After one head has been replaced and adjusted, replace the other head. Do not remove all the heads at the same time.

Settings:

- TAPE SELECT switch: BIAS → LOW
EQ → NORMAL
- MONITOR switch: TAPE
- TAPE SPEED switch: 19 cm or 9.5 cm (7½ or 3¾)
- PB LEVEL control: mechanical mid
- LINE control: normal position (See page 10.)

Procedure:

1. Thread a tape, and by turning head zenith and head height adjustment screws, adjust the head height as shown.

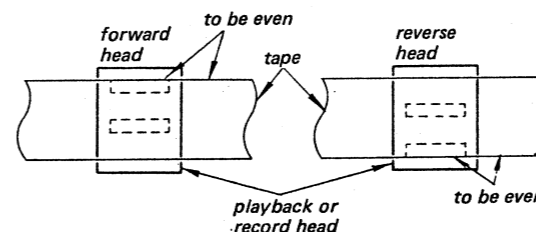

2. Mode: record
MONITOR switch: TAPE

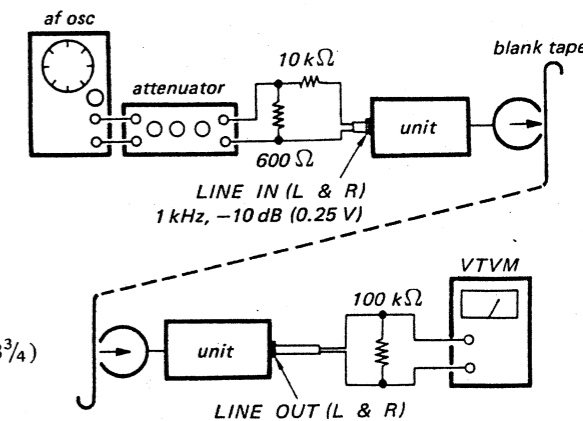

Adjust the head zenith and head height adjustment screws for maximum reading on the VTVM.

3. Perform the playback head azimuth and phase adjustments on Page 13 or the record head azimuth adjustment on Page 15.
4. After completing the adjustment, apply locking compound to the adjustment screws.

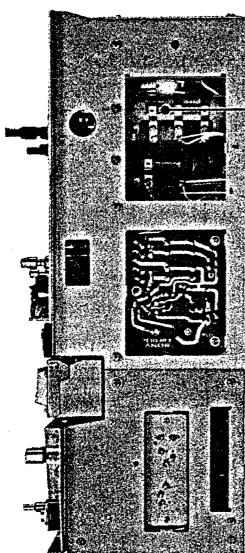

Back Tension Torque Adjustment

1. Measurement

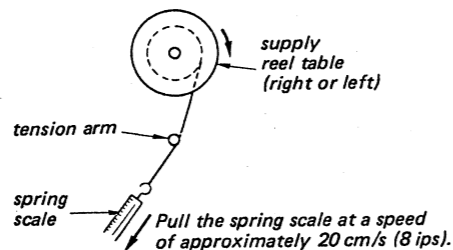

Specifications:

Mode	Back Tension Torque
fast forward, rewind	40 ~ 50 g·cm (0.55 ~ 0.7 oz·inch)
forward, reverse playback	200 ~ 240 g·cm (2.78 ~ 3.34 oz·inch)

2. If necessary, adjust the torque by moving the slider of R901 and R902.

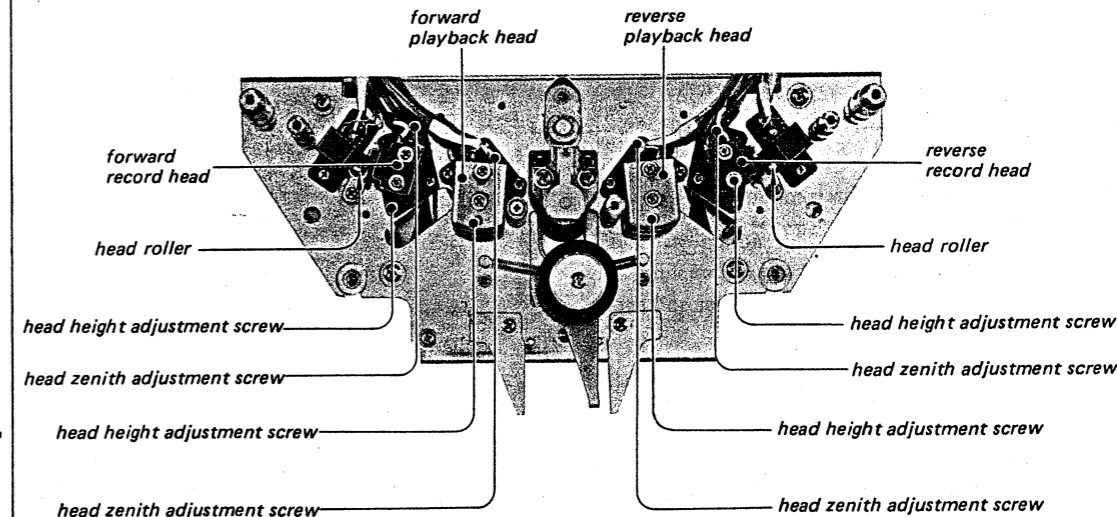
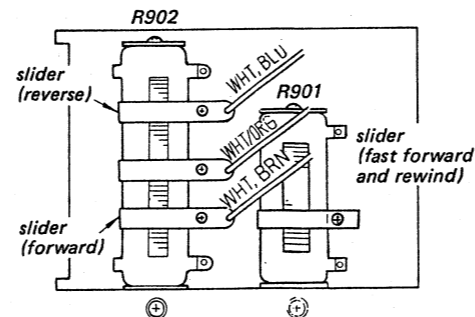

3-2. ELECTRICAL ADJUSTMENTS

Precaution:

- Clean the following parts with a swab moistened with alcohol:

record heads	pinch roller
playback heads	rubber belts
erase heads	idlers
capstan	tape guides
- Demagnetize record, playback and erase heads with a head demagnetizer.
- Do not use magnetized screwdriver for adjustments.
- After adjustments, apply locking compound to the adjusted parts.
- Adjustments should be performed in the order listed in this service manual.
- Adjustments and measurements should be performed for each L and R channel with the rated power supply voltage unless otherwise specified.
- Unless otherwise noted, set controls and switches as follows:

TAPE SELECT switch ... EQ + NORMAL
 BIAS -> LOW
 MONITOR switch TAPE
 TAPE SPEED switch 19 cm (7 1/2)
 MIC ATT switch OFF
 AUTO REV switch NON REV

Test Equipment/Tools Required:

- audio oscillator (af osc)
- VTVM
- VOM
- attenuator (600 Ω)
- digital frequency counter or speed checker (SONY LFM-30)
- resistors: 600 Ω, 10 kΩ, 100 kΩ
- SONY test tapes: 1). J-19-F2

Tone:	1	2	3	4	5	6	7
Frequency (Hz)	400	400	10 k	12.5 k	7 k	80	40
Level (dB):	0	-10	-10	-10	-10	-10	-10

- SPC-47 (4 kHz, 0 dB) blank tape (completely erased): SLH-S1

Normal Input Level

	Impedance	Level
LINE IN	10 kΩ	-10 dB (0.25 V)

Normal Output Level

	Load Impedance	Level
LINE OUT	100 kΩ	-5 dB (0.44 V)

Normal LINE control setting:

MIC control: MIN
 PB LEVEL control: mechanical mid
 TAPE SELECT switch: EQ + SLH
 BIAS -> LOW
 MONITOR switch: TAPE

Mode: record

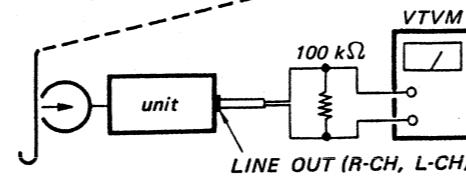
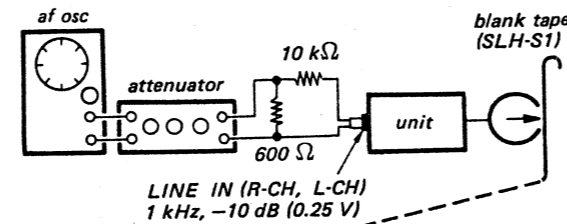

Adjust LINE control for -5 dB (0.44 V) reading on the VTVM.

1. 24 V B⊕ Adjustment

Procedure:

Mode: stop

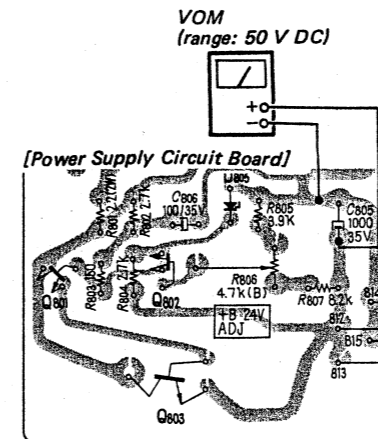

Adjust R806 for 24 V reading on the VOM.

2. Tape Speed Adjustment

Settings:

TAPE SPEED switch: 19 cm and 9.5 cm (7 1/2 and 3 3/4)

Procedure:

- Mode: playback

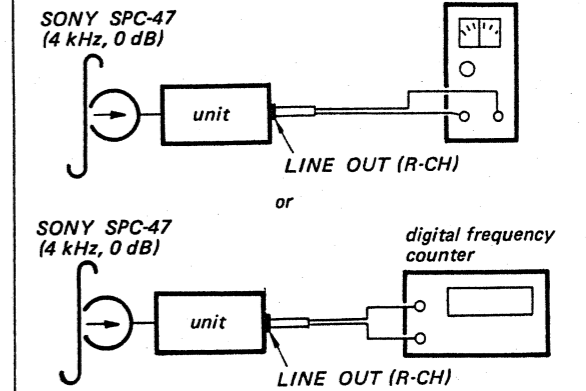

TAPE SPEED	Adjust	Specification	
		speed checker	digital frequency counter
19 cm, 7 1/2	R718	-1 ~ +1 %	3,960 ~ 4,040 Hz
9.5 cm, 3 3/4	R719	-1 ~ +1 %	1,980 ~ 2,020 Hz

Adjustment Location:

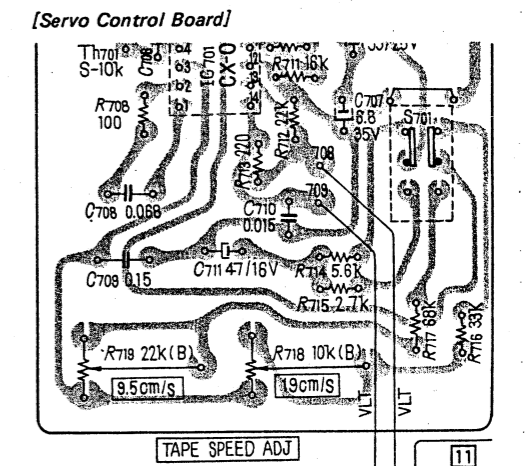

3. Playback Head Azimuth and Phase Adjustments

Settings:

TAPE SPEED switch: 19 cm (7 1/2)

Procedure:

1. Mode: playback

SONY J-19-F2 (3rd tone)
(10 kHz, -10 dB)

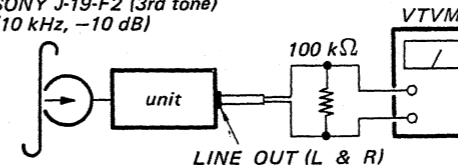

Turn the adjustment screw for the highest reading on the VTVM.

Note: If the highest peak readings at L-CH and R-CH cannot be obtained at the same screw position, take the midway between the both positions of the screw.

2. Mode: playback

SONY J-19-F2 (2nd tone)
(400 Hz, -10 dB)

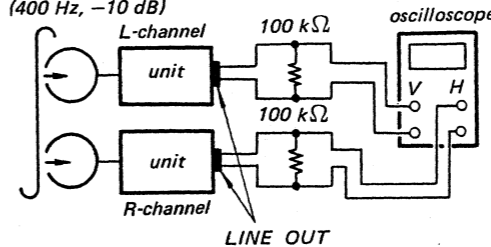

Adjust	On the oscilloscope			
azimuth adjustment screw				
	good		wrong	

Adjustment Location:

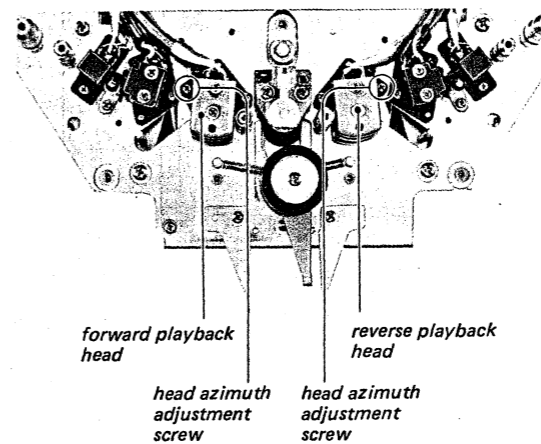

4. Playback Level Adjustment

Procedure:

1. Mode: playback

SONY J-19-F2
(1st tone, 400 Hz 0 dB)

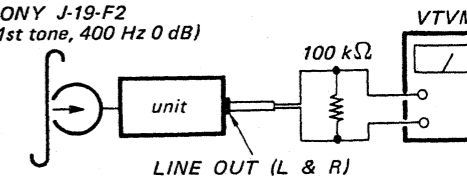

TAPE SELECT (EQ) switch: NORMAL

Mode	Adjust	VTVM reading
forward playback	R316 (L-CH) R416 (R-CH)	-5.5 dB ~ -4.5 dB (0.41 V ~ 0.45 V)
reverse playback	R315 (L-CH) R415 (R-CH)	

TAPE SELECT (EQ) switch: SPECIAL

Mode	Adjust	VTVM reading
forward playback	R316 (L-CH) R416 (R-CH)	-8 dB ~ -7 dB (0.31 V ~ 0.35 V)
reverse playback	R315 (L-CH) R415 (R-CH)	

Adjustment Location:

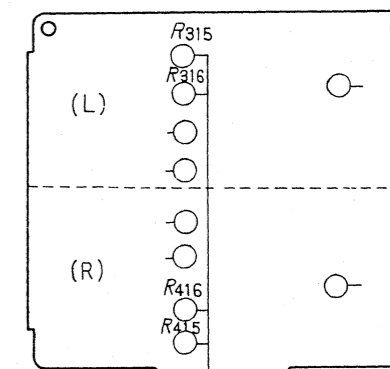

playback level adj.
forward: R316, 416
reverse: R315, 415

playback circuit board
(conductor side)

5. Playback Equalizer Adjustment

Settings:

TAPE SELECT (EQ) switch: SPECIAL

Procedure:

Mode: playback
SONY J-19-F2
2nd tone, 400 Hz, -10 dB
3rd tone, 10 kHz, -10 dB

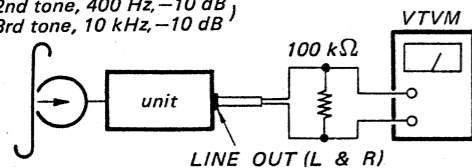

Mode	Adjust	Remarks
forward playback	R314 (L-CH) R414 (R-CH)	Adjust so that 10 kHz level is the same as 400 Hz.
reverse playback	R313 (L-CH) R413 (R-CH)	

Specification:

J-19-F2		Level Difference from 2nd tone (400 Hz)
Tone	Frequency	
2nd	400 Hz	0 dB (reference)
3rd	10 kHz	0 ± 2 dB
4th	12.5 kHz	0 ± 2 dB
5th	7 kHz	0 ± 2 dB
6th	80 Hz	+1 ± 2.5 dB
7th	40 Hz	+3 ± 2.5 dB

Adjustment Location:

playback equalizer adj.
forward: R314, 414
reverse: R313, 413

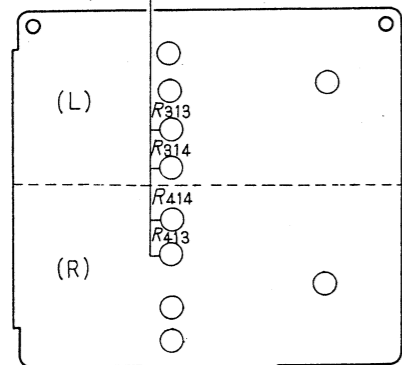

playback circuit board (conductor side)

6. Level Meter Calibration

Settings:

MONITOR switch: SOURCE
PB LEVEL control: mechanical mid

Procedure:

1. Mode: record

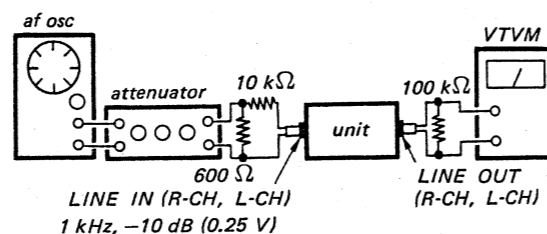

2. Adjust LINE IN control for -5 dB (0.44 V) reading on the VTVM.
3. Calibrate the level meters for "0" indication.

Adjust	Level Meter Reading
R333 (L-CH)	"0" VU
R433 (R-CH)	

Adjustment Location:

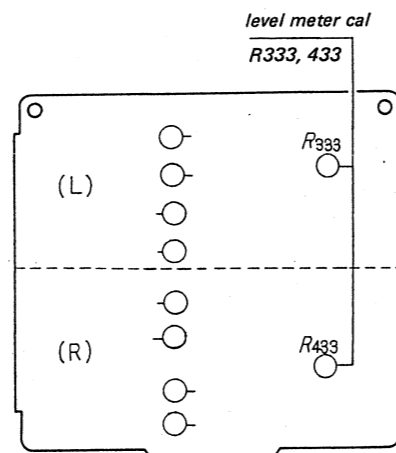

playback circuit board (conductor side)

7. Record Head Azimuth Adjustment

Settings:

TAPE SELECT (EQ) switch: SPECIAL
TAPE SELECT (BIAS) switch: LOW
LINE control: normal setting on page 11

Procedure:

1. Mode: record

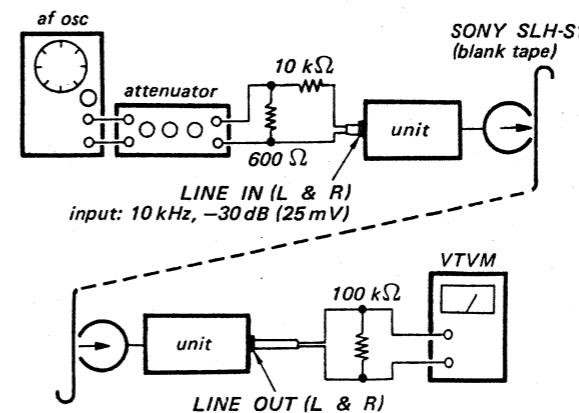

Turn the adjustment screw for the highest reading on the VTVM.

Note: If the highest peak readings at L-CH and R-CH cannot be obtained at the same screw position, take the midway between the both positions of the screw.

Adjustment Location:

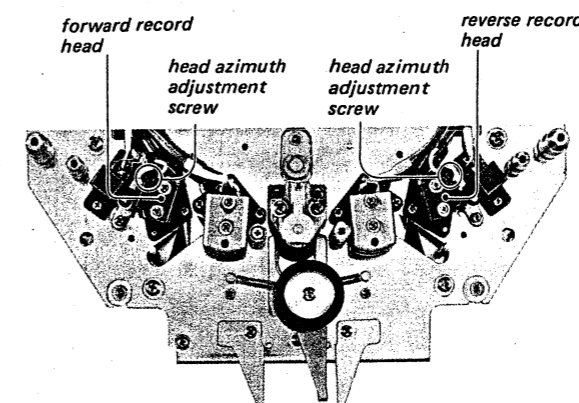

8. Record Bias and Bias Frequency Adjustment

Settings:

TAPE SELECT (EQ) switch: SPECIAL
TAPE SELECT (BIAS) switch: LOW
LINE control: normal setting on page 11

Procedure:

1. Mode: record

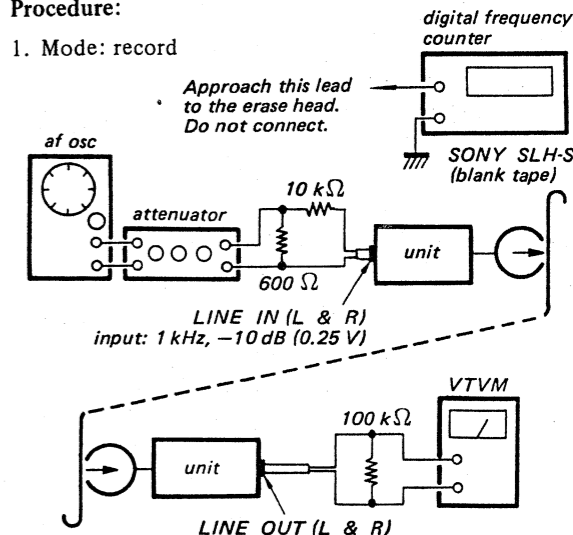

Mode	Adjust	Remarks
forward record	trimmer capacitor C512 (L-CH) C513 (R-CH)	Slowly turn the trimmer capacitor clockwise until VTVM reads 0.5 dB below and beyond the maximum reading as shown.
reverse record	trimmer capacitor C514 (L-CH) C515 (R-CH)	

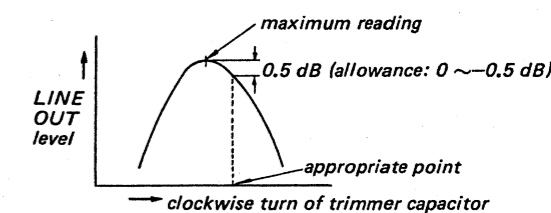

- In forward record mode, be sure that the frequency counter reading is as specified.
Specification: 160 ± 3 kHz
- In reverse record mode, adjust the trimmer capacitor C508 until VTVM reads the same frequency as step 2.

Adjustment Location: See Fig. A. on next page.

Adjustment Location:

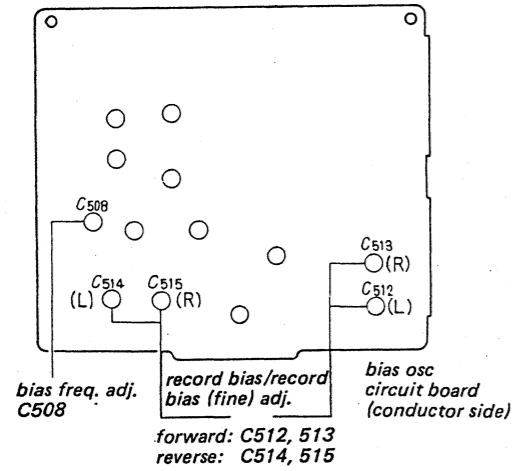

Fig. A. Record bias and frequency, record bias fine adjustment location

9. Record Bias Fine Adjustment

Note: Perform this adjustment after the record bias and bias frequency adjustment.

Settings:

TAPE SELECT (EQ) switch: SPECIAL
LINE control: normal setting on page 11

Procedure:

1. Mode: record

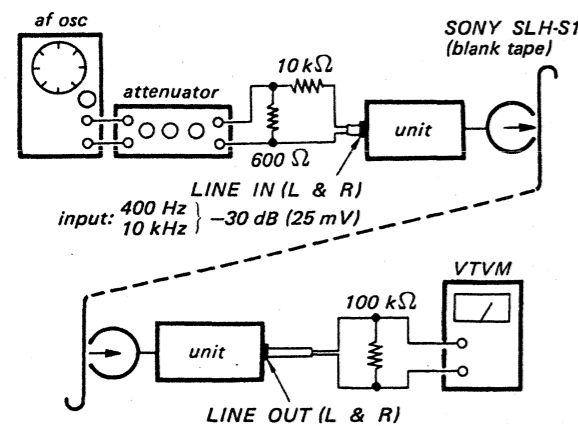

Mode	Frequency	Adjust	Remarks
forward record	400 Hz	trimmer capacitor C512 (L-CH) C513 (R-CH)	Adjust so that 10 kHz level is the same as 400 Hz.
	10 kHz		
reverse record	400 Hz	trimmer capacitor C514 (L-CH) C515 (R-CH)	
	10 kHz		

Adjustment Location: See Fig. A above.

10. Record Level Adjustment

Settings:

SPEED SELECT switch: 19 cm and 9.5 cm (7 1/2 and 3 3/4)
TAPE SELECT (EQ) switch: SPECIAL
LINE control: normal setting on page 11

Procedure:

1. Mode: record

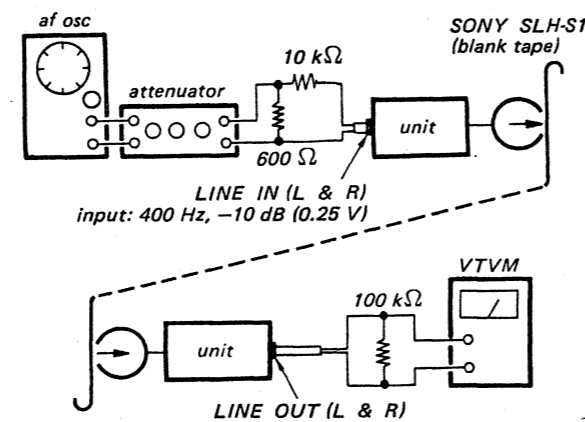

Mode	Tape Speed	Adjust	VTVM Reading
forward record	19 cm/s (7 1/2)	R125 (L-CH)	-5 dB±0.5 dB (0.41~0.45 V)
	9.5 cm/s (3 3/4)	R225 (R-CH)	-5 dB±2 dB (0.35~0.55 V)
reverse record	19 cm/s (7 1/2)	R126 (L-CH)	-5 dB±0.5 dB (0.41~0.45 V)
	9.5 cm/s (3 3/4)	R226 (R-CH)	-5 dB±2 dB (0.35~0.55 V)

Adjustment Location:

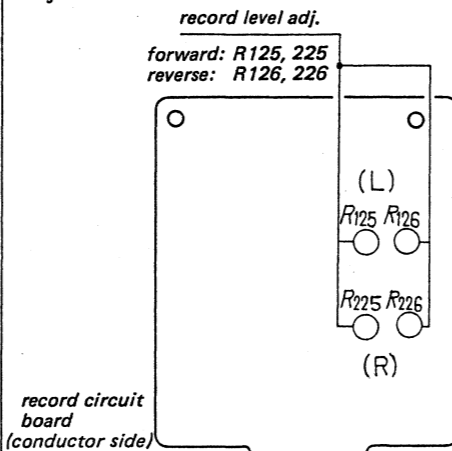

11. Dummy Coil Adjustment

Settings:

TAPE SELECT (EQ) switch: SPECIAL
LINE control: normal setting on page 11

Procedure:

1. Mode: record

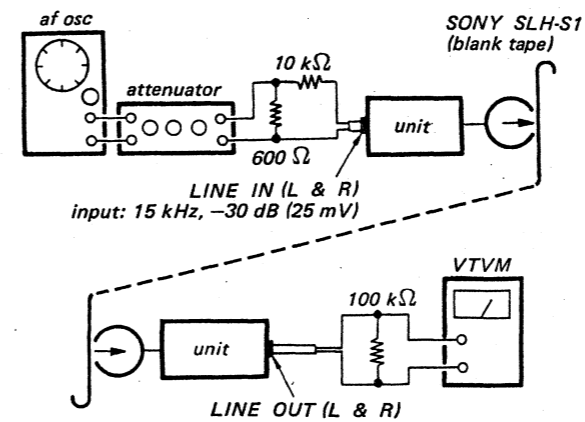

Step	Mode	Adjust	VTVM Reading
1	stereo record	—	Memorize
2	R channel record forward:	L506	R-ch: same as in stereo record mode
	reverse:	L508	
3	L channel record forward:	L505	L-ch: same as in stereo record mode
	reverse:	L507	

Adjustment Location:

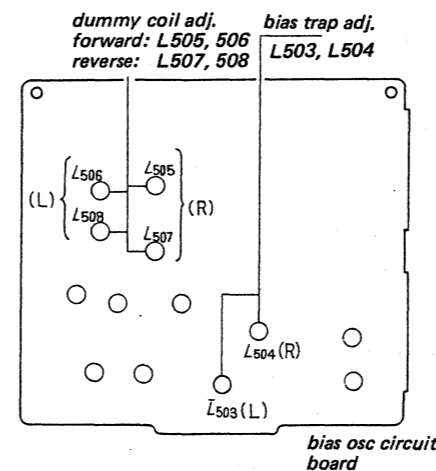

Fig. B. Dummy coil and bias trap adjustment location

12. Bias Trap Adjustment

Settings:

MONITOR switch: SOURCE

Procedure:

1. Mode: forward stereo record

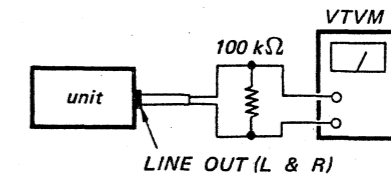

Be sure that the VTVM reading is less than -40 dB (7.7 mV).

2. Test Setup (forward stereo record mode).

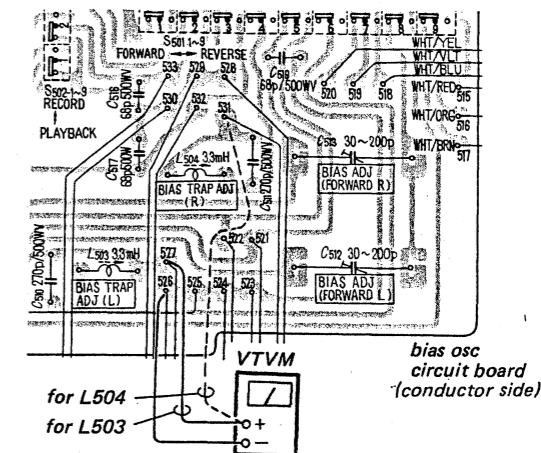

Adjust	VTVM reading
L503	minimum
L504	minimum

Adjustment Location: See Fig. B on the left.

SECTION 4
DIAGRAMS

4-1. SCHEMATIC DIAGRAM - System Control Section -

[FUNCTION SWITCH CIRCUIT BOARD]

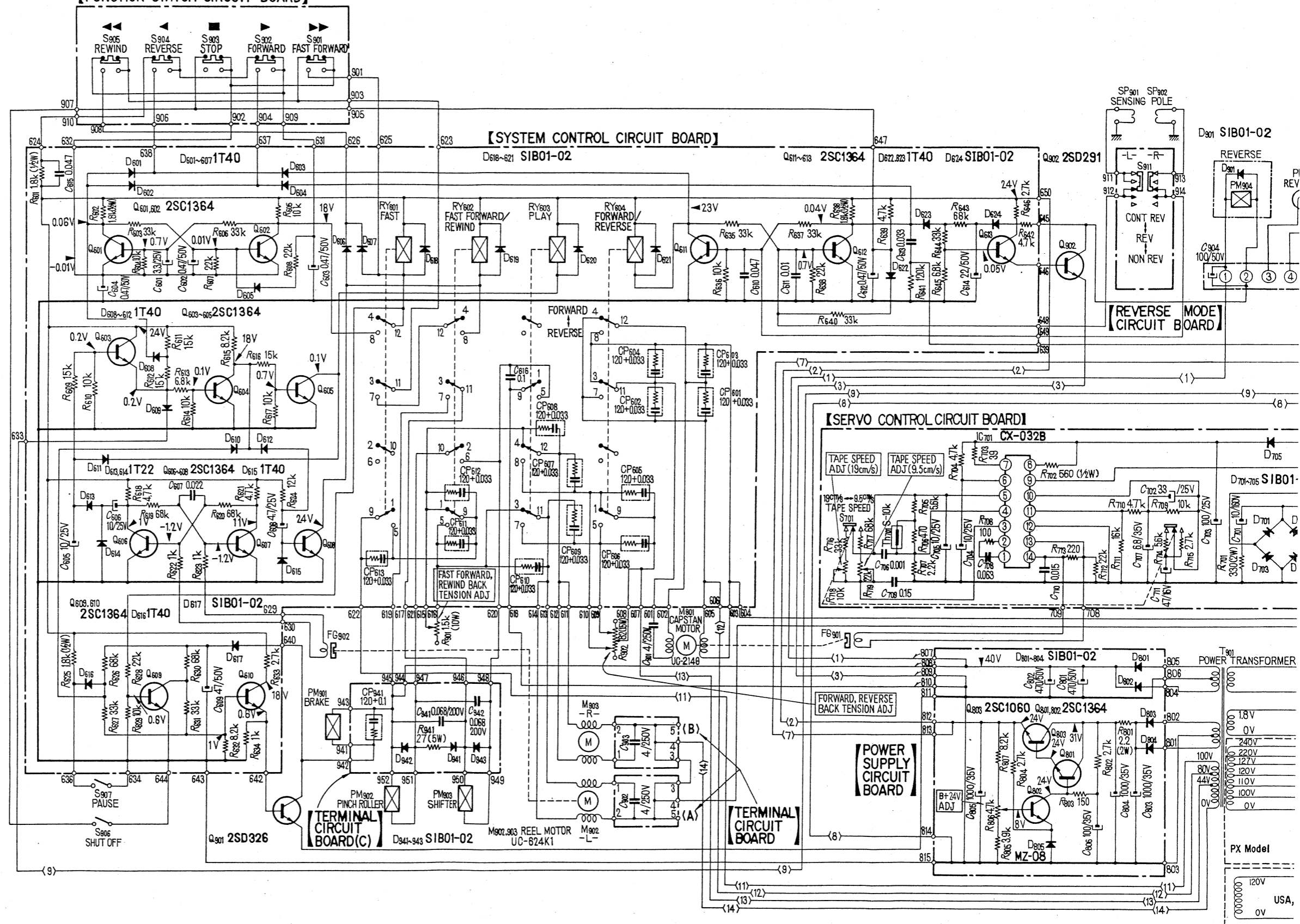

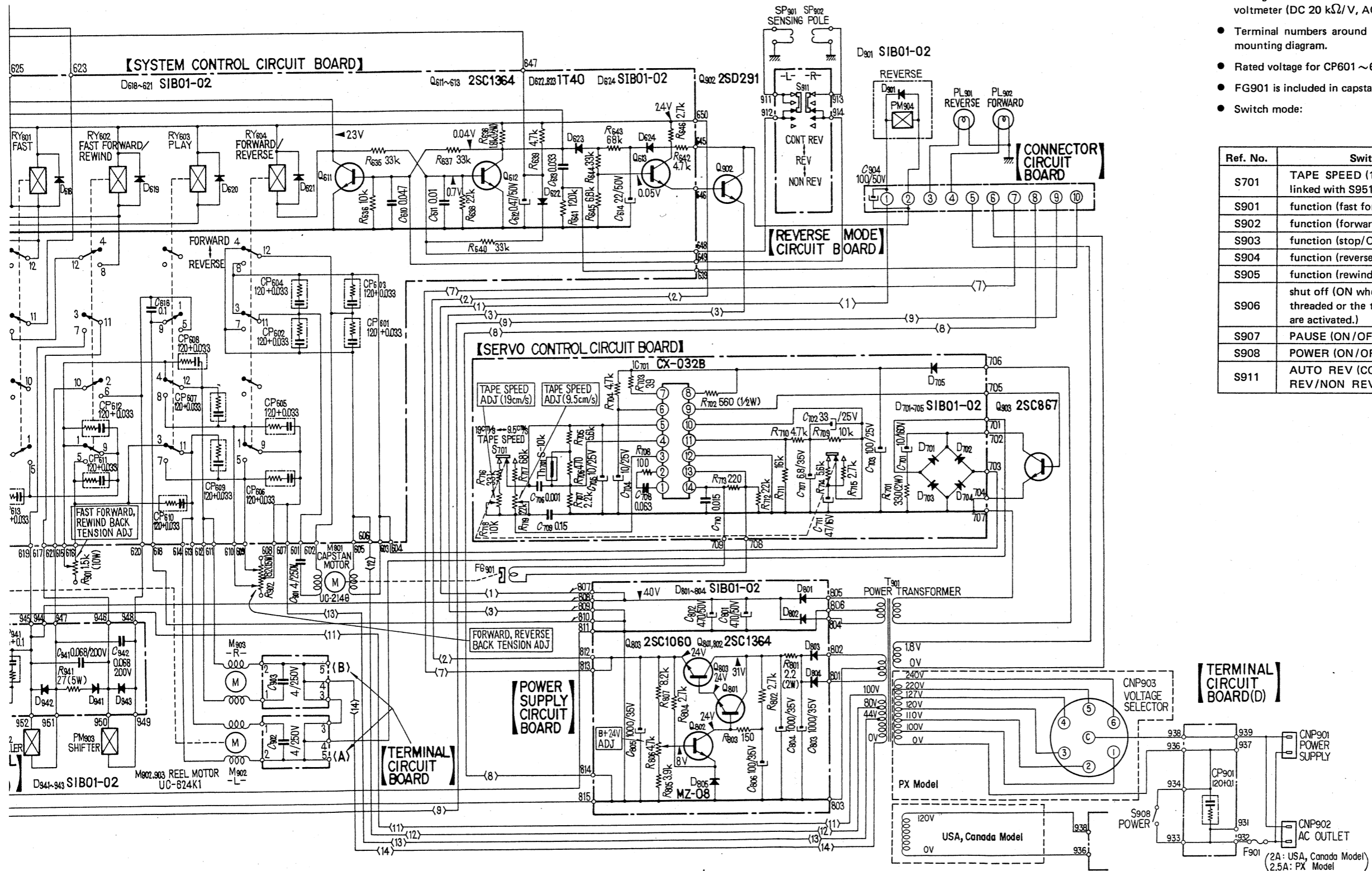

Note:

- All resistors are in Ω , $\frac{1}{4} W$, and carbon type unless otherwise indicated. (k = 1000)
- All capacitors are in μF unless otherwise indicated. (p = $\mu\mu$)
- Voltage values shown are measured to chassis ground with a voltmeter (DC 20 k Ω/V , AC 8 k Ω/V) in forward mode.
- Terminal numbers around the circuit boards are equivalent to the mounting diagram.
- Rated voltage for CP601 ~ 613 and CP941 is 500 V.
- FG901 is included in capstan motor (M901).
- Switch mode:

Ref. No.	Switch	Mode
S701	TAPE SPEED (19 cm/9.5 cm, linked with S951)	19 cm
S901	function (fast forward/OFF)	OFF
S902	function (forward/OFF)	OFF
S903	function (stop/OFF)	OFF
S904	function (reverse/OFF)	OFF
S905	function (rewind/OFF)	OFF
S906	shut off (ON when the tape is threaded or the tension arms are activated.)	ON
S907	PAUSE (ON/OFF)	OFF
S908	POWER (ON/OFF)	OFF
S911	AUTO REV (CONT REV/REV/NON REV)	CONT REV

4-2. MOUNTING DIAGRAM — System Control Section —
— Conductor Side —

TC-558 TC-558

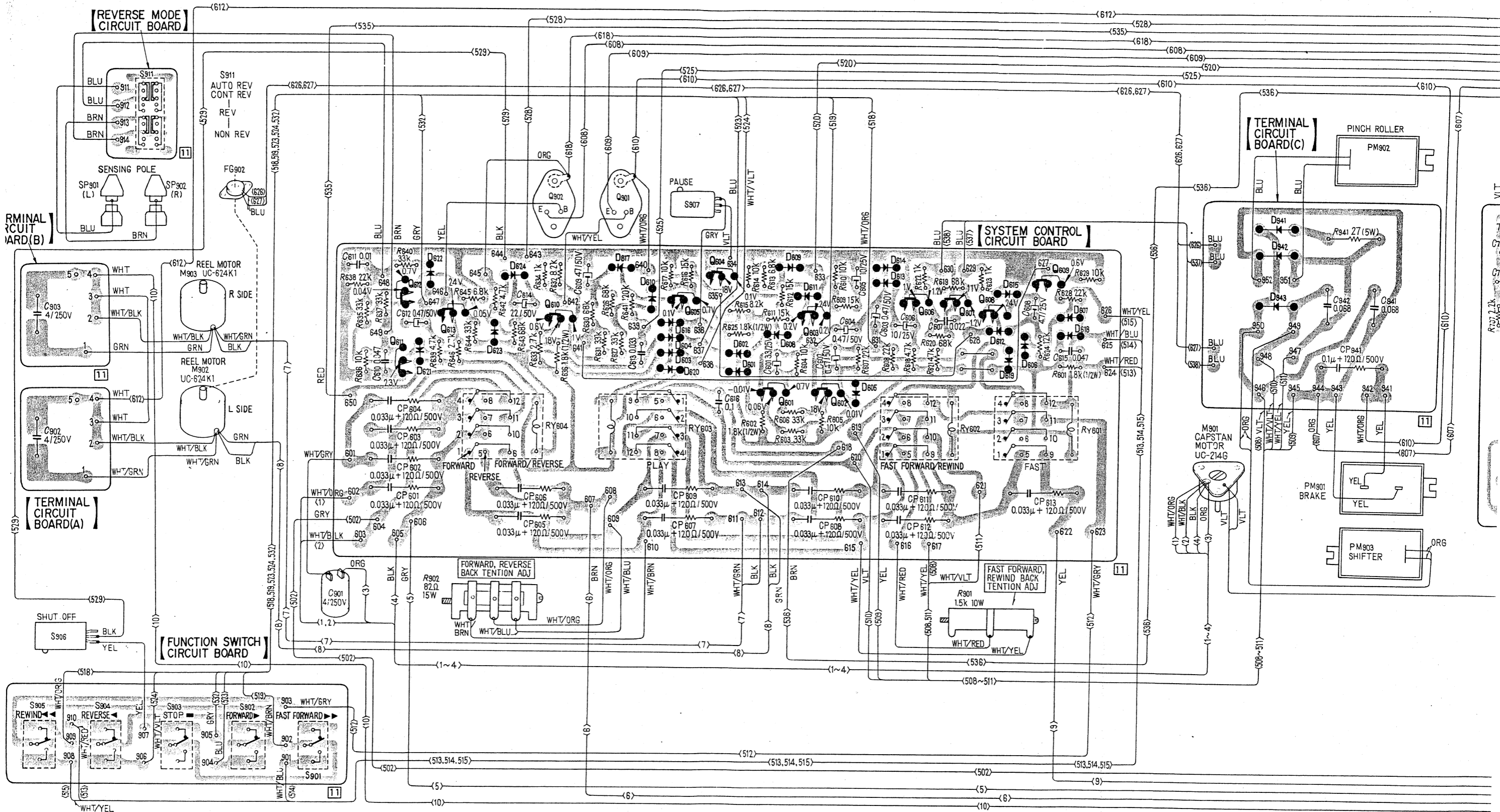

Q, IC	Q612 Q611	Q613	Q610	Q605	Q604	Q601	Q603 Q602	Q606	Q607	Q608	Q609
D	D622 D621	D624 D623	D617	D616 D604 D603 D620	D602 D601	D609 D608 D611	D614 D613	D615 D612 D606 D619	D607	D618	D941 D942 D943
ADJ		R902								R901	

TC-558 TC-558

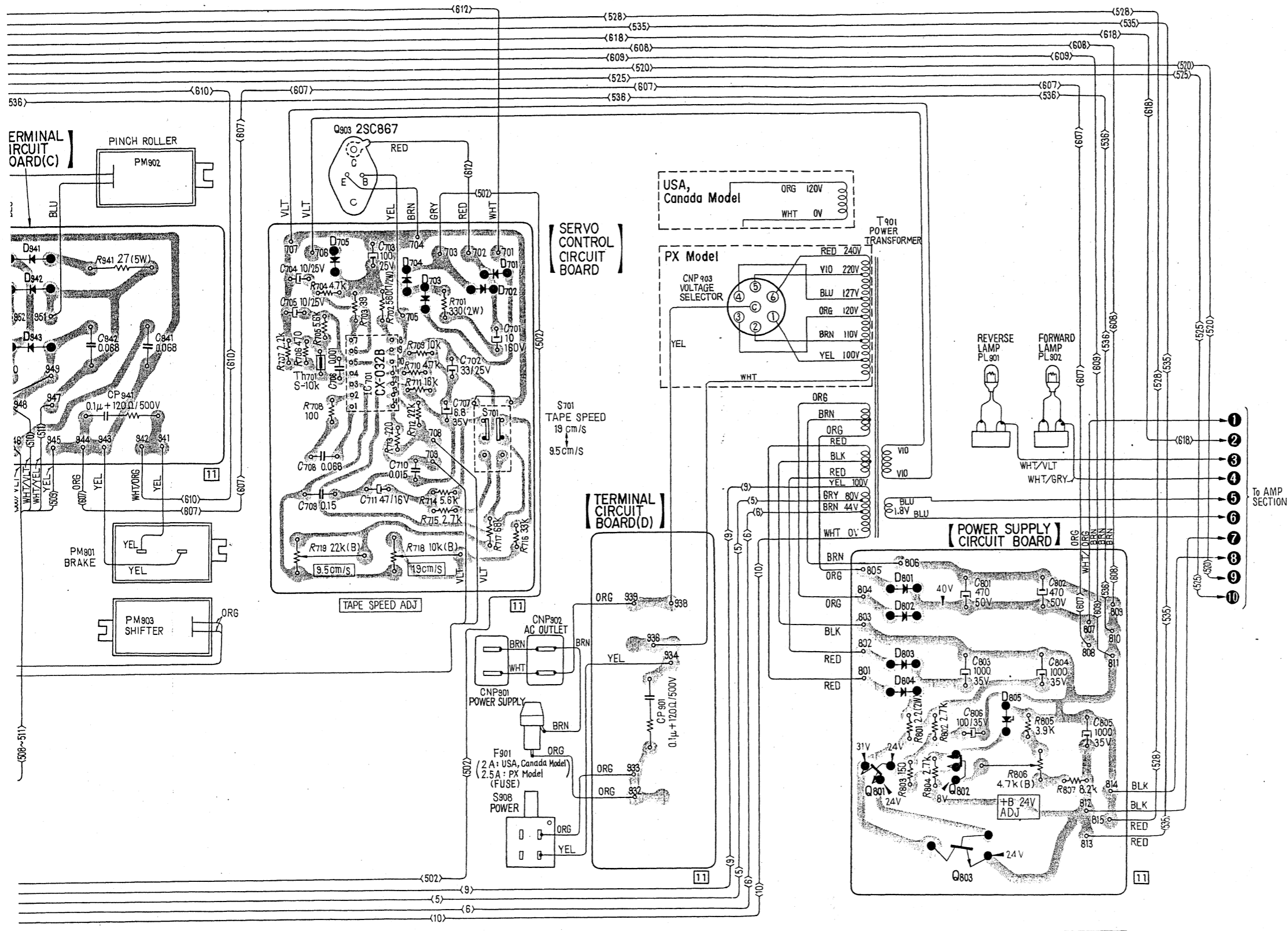

D601 ~ D612, D615 } 1T40
D616, D622, D623 }

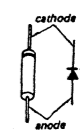

D617, D618 ~ D621, D624 } S1B01-02
D701 ~ D705, D801 ~ D804 }
D901, D941 ~ D943 }

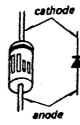

D805: MZ-08

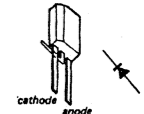

Q601 ~ Q613 } 2SC1364
Q801, Q802 }

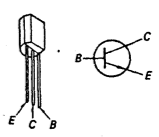

Q901: 2SD326
Q902: 2SD291
Q903: 2SC867

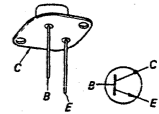

Q803: 2SC1060

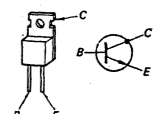

IC701: CX-032B

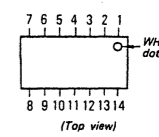

D941	D705	D704	D701	Q801	Q802
D942		D703	D702	D801	Q803
D943				D802	
				D803	D805
				D804	
	R719	R718			R806

TC-558 TC-558

4.3. MOUNTING DIAGRAM – Amp Section –
– Conductor Side –

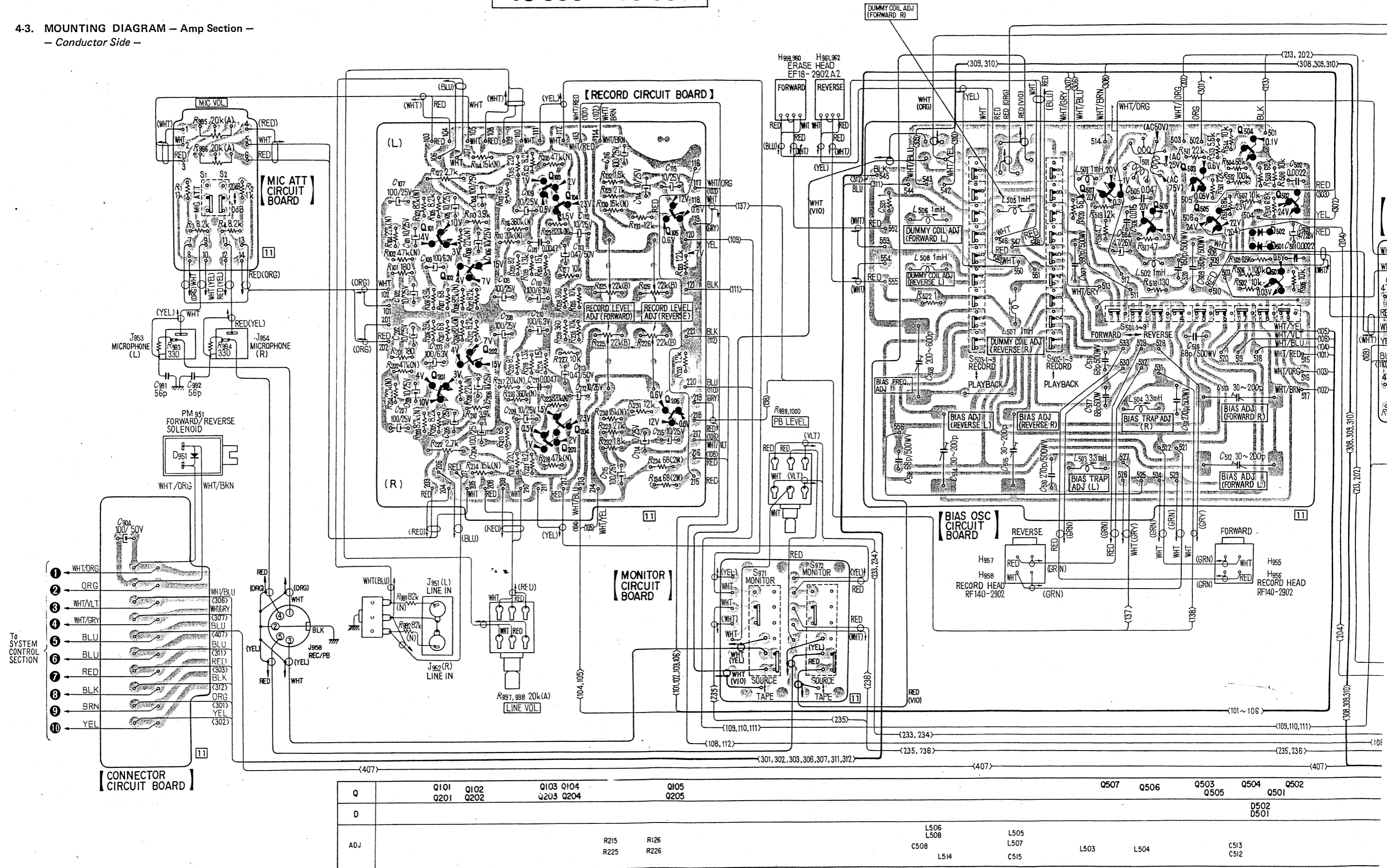

Q	Q101	Q102	Q103	Q104	Q105	Q507	Q506	Q503	Q504	Q502
D	Q201	Q202	Q203	Q204	Q205					D502
ADJ			R215	R216		L506	L505			D501
			R225	R226		L508	L507			
						C508	C515	L503	L504	C513
						L514				C512

TC-558 TC-558

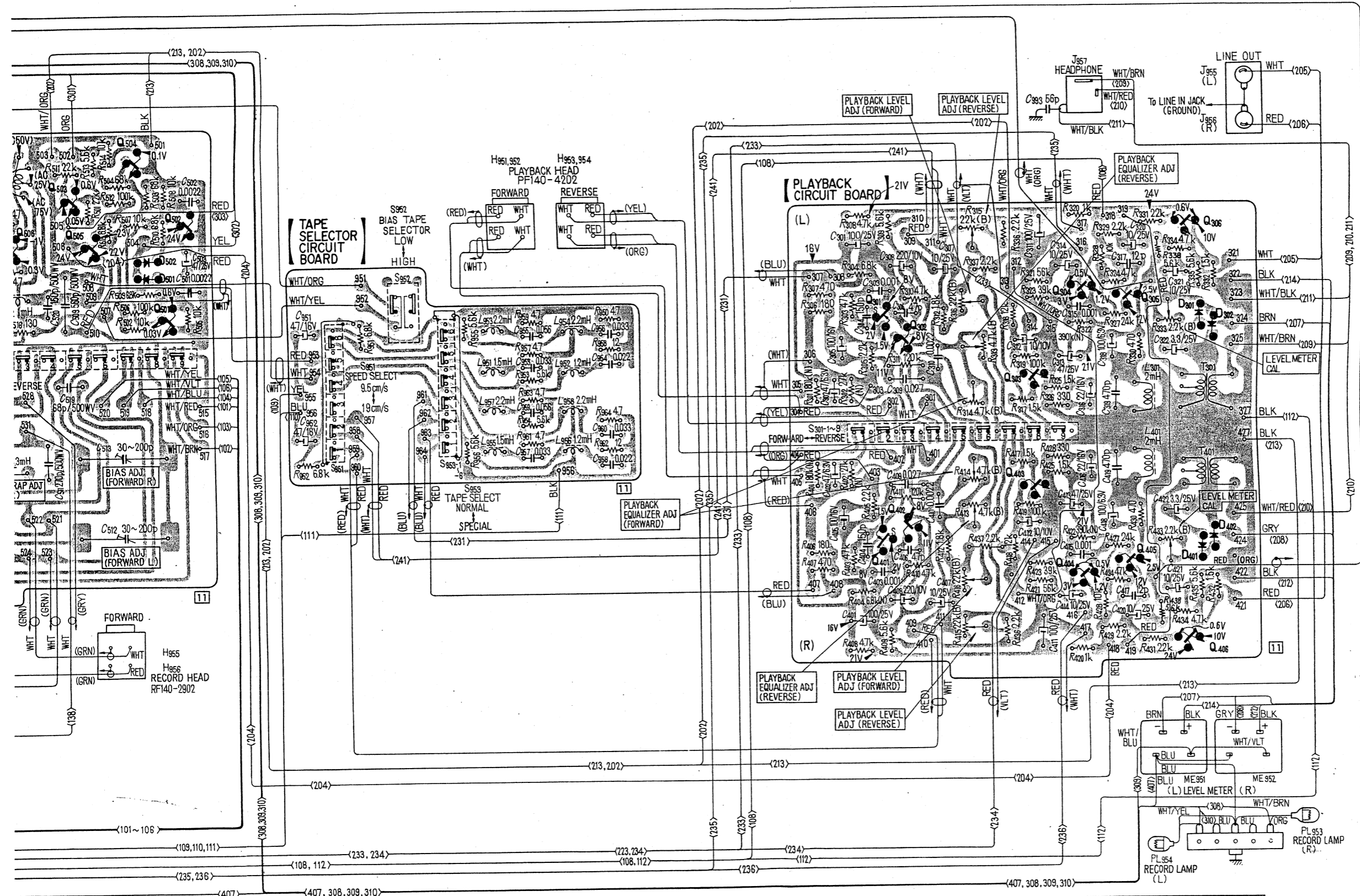

Q101, Q103, Q201, Q203
Q302, Q304, Q402 ~ Q404 2SC136

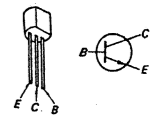

Q102, Q202: 2SA678

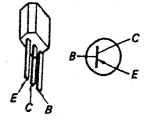

Q104, Q105, Q204, Q205
Q303, Q305, Q306, Q405 2SC1364
Q406, Q501 ~ Q507

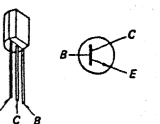

Q301, Q401: 2SK43

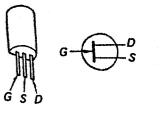

D301, D302, D401, D402: 1T22
D501, D502: 1T40

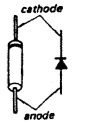

D951: 10D2

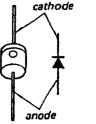

1506	Q503 Q505	Q504	Q502 Q501	Q301 Q401	Q302 Q402	Q303 Q403	Q304 Q404	Q305 Q405	Q306 Q406
	D502 D501								D301 D302 D401 D402
						R315 R316 R314 R313			R333
						R416 R414 R415 R413			R433

The portions indicated by RED show PX Model only.

TC-558 TC-558

4-4. SCHEMATIC DIAGRAM - Amp Section -

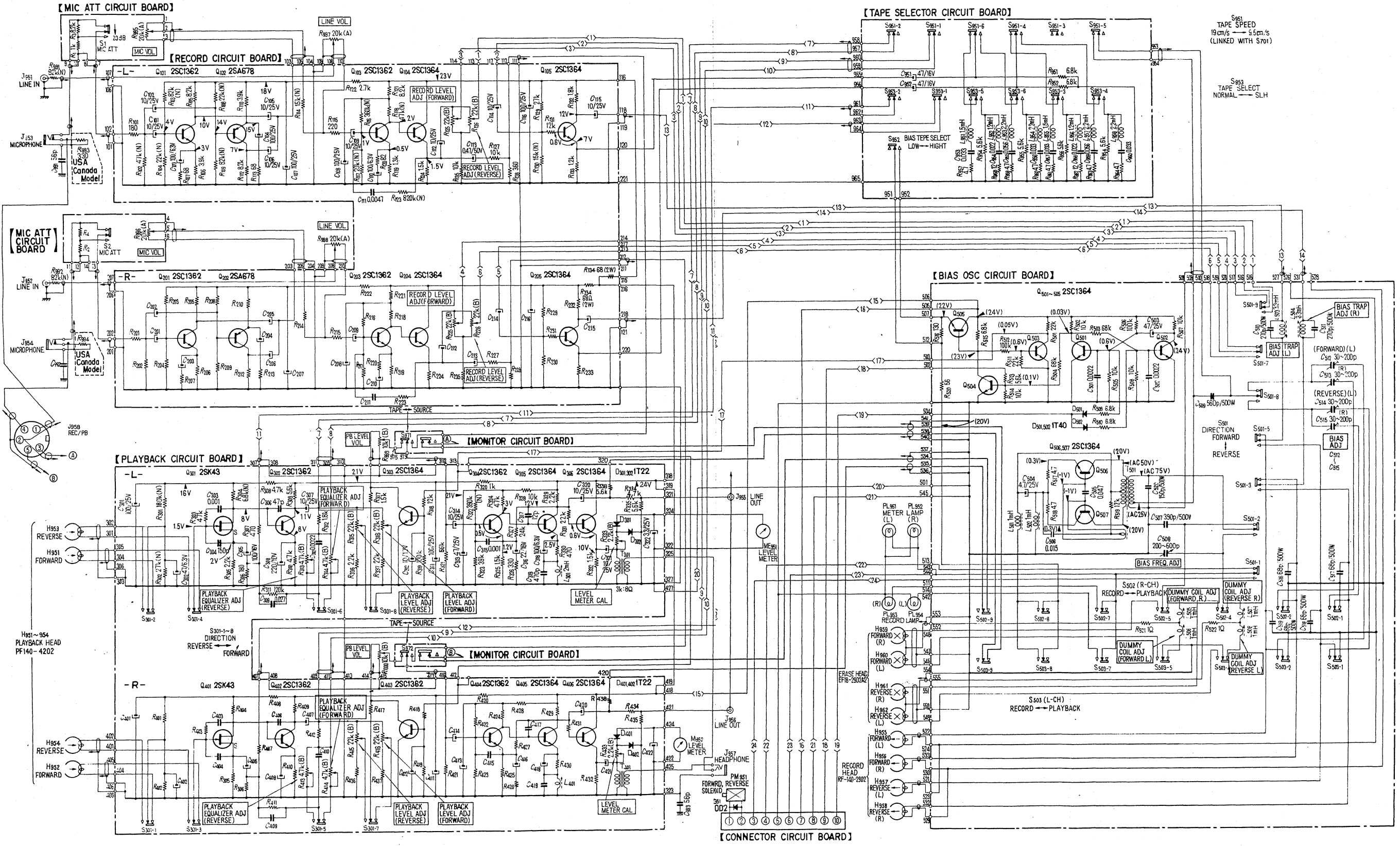

The portions indicated by RED show PX Model only.

● Switch mode:

Ref. No.	Switch	Mode
S1.2	MIC ATT (20 dB/OFF)	OFF
S301, 501	direction (forward/reverse)	forward
S502, 503	record/playback	playback
S951	TAPE SPEED (19 cm/9.5 cm, linked with S701)	19 cm
S952	BIAS (TAPE SELECT, LOW/HIGH)	LOW
S953	EQ (TAPE SELECT, NORMAL/SPECIAL)	NORMAL
S971, 972	MONITOR (SOURCE/TAPE)	TAPE

Note: ● All resistors are in Ω , $\frac{1}{2}$ W and carbon type unless otherwise indicated. (k = 1000)

● All capacitors are in μ F unless otherwise indicated. (p = μ F)

● Terminal numbers around the circuit boards are equivalent to the mounting diagram.

● PL951, 952 are included in level meter (ME951, 952).

● Voltage values shown are measured to chassis ground with a voltmeter (DC 20 k Ω /V, AC 8 k Ω /V) in playback mode. Voltages in () are for record mode. AC voltages in bias osc circuit are measured with VTVM.

4-5. LEVEL DIAGRAM
- Record Mode -

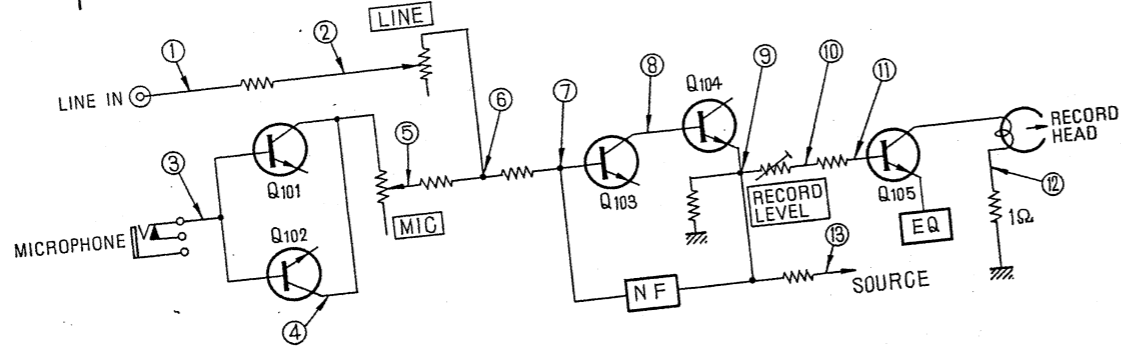
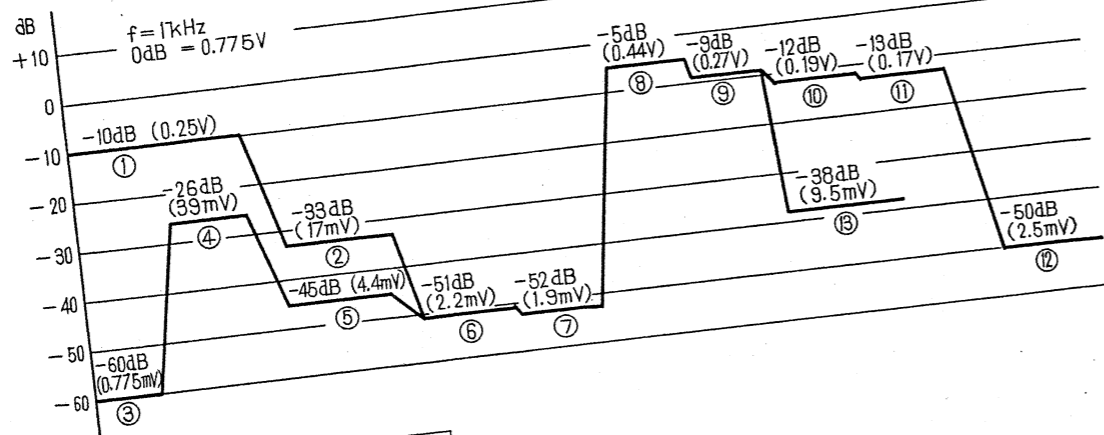

- Playback Mode -

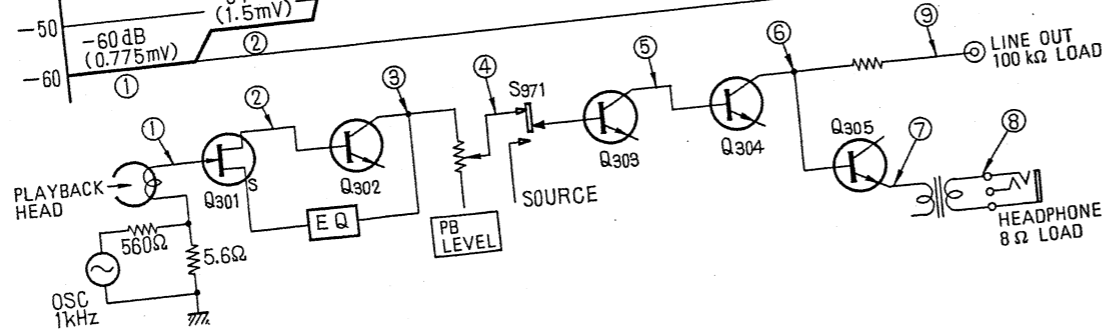
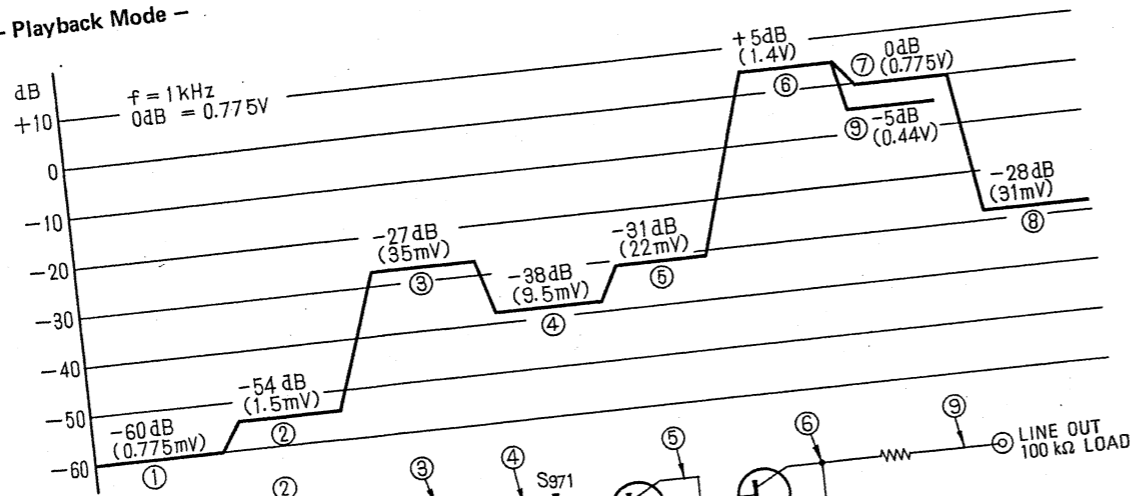

MEMO

Handwritten notes area with horizontal lines.

SECTION 5
EXPLODED VIEWS

5-1. EXPLODED VIEW (1)

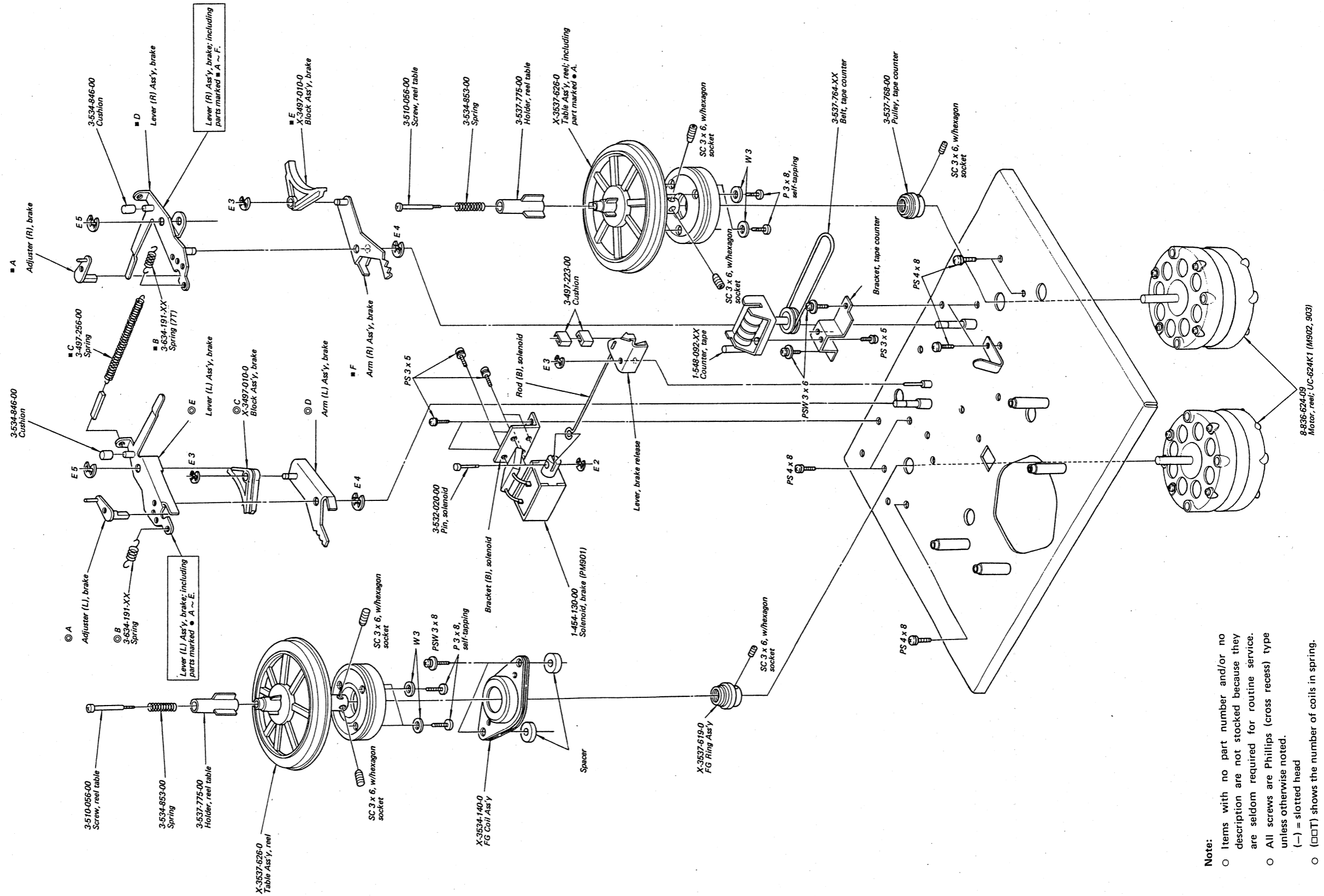

Note:

- Items with no part number and/or no description are not stocked because they are seldom required for routine service.
- All screws are Phillips (cross recess) type unless otherwise noted.
- (-) = slotted head
- (□TT) shows the number of coils in spring.

5-4. EXPLODED VIEW (4)

Button Ass'y, record; including parts marked * A ~ Z.

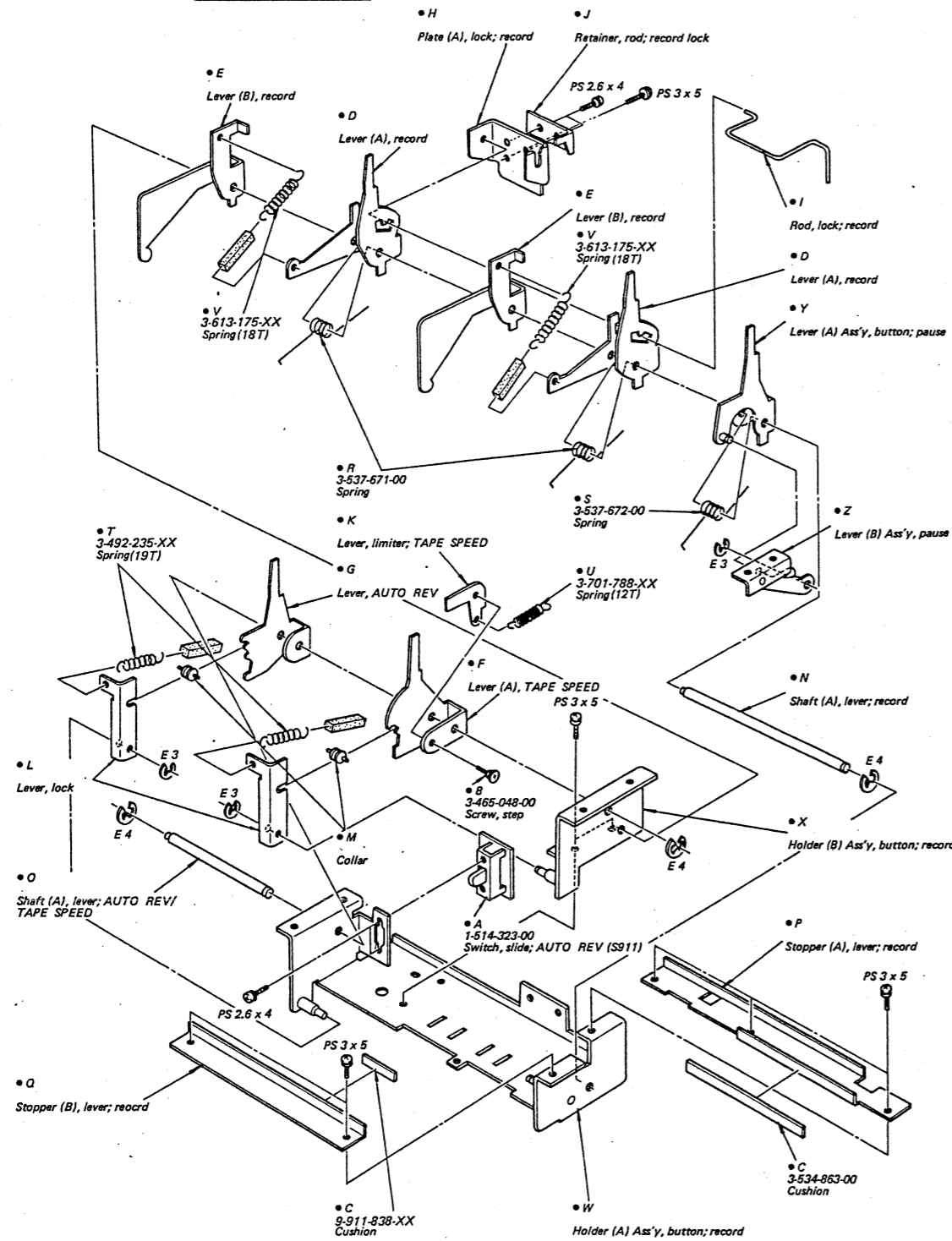

- Note:
- Items with no part number and/or no description are not stocked because they are seldom required for routine service.
 - All screws are Phillips (cross recess) type unless otherwise noted.
(-) = slotted head
 - (□T) shows the number of coils in spring.

5-3. EXPLODED VIEW (3)

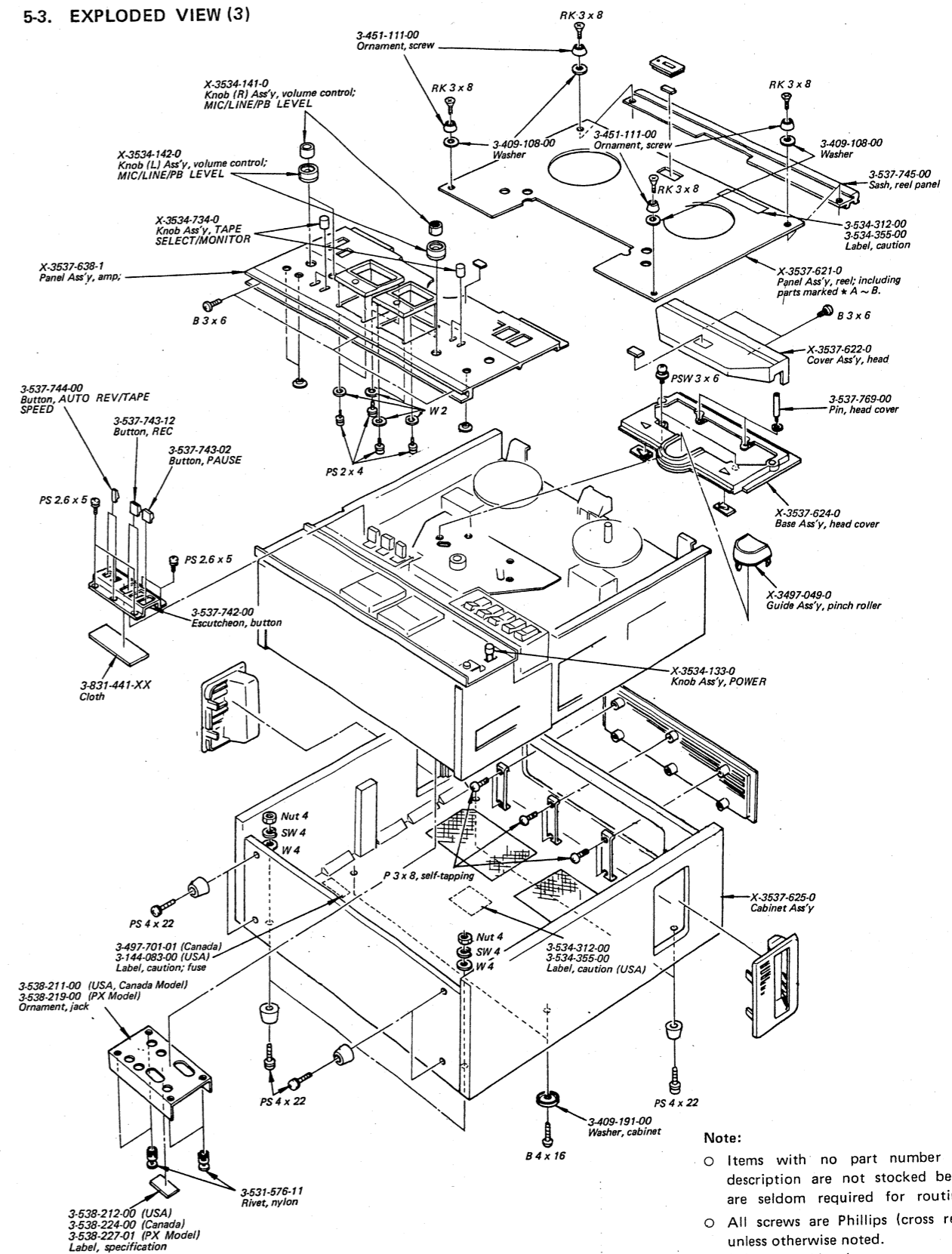

- Note:
- Items with no part number and/or no description are not stocked because they are seldom required for routine service.
 - All screws are Phillips (cross recess) type unless otherwise noted.
(-) = slotted head

SECTION 6

PARTS LIST

Ref. No. Part No. Description

SEMICONDUCTORS

Q101, 201	Transistor	2SC1362
Q102, 202	Transistor	2SA678
Q103, 203	Transistor	2SC1364
Q104, 204	Trnasistor	2SC1362
Q105, 205	Transistor	2SC1362
Q301, 401	FET	2SK43
Q302, 402	Transistor	2SC1362
Q303, 403	Transistor	2SC1364
Q304, 404	Transistor	2SC1362
Q305, 405	Transistor	2SC1364
Q306, 406	Transistor	2SC1364
Q501 ~ 507	Transistor	2SC1364
Q601 ~ 613	Transistor	2SC1364
Q801	Transistor	2SC1060
Q802, 803	Transistor	2SC1364
Q901	Transistor	2SD326
Q902	Transistor	2SD291
Q903	Transistor	2SC867
IC701	Integrated Circuit	CX-032B
D301, 401	Diode	1T22
D302, 402	Diode	1T22
D501, 502	Diode	1T40
D601 ~ 612	Diode	1T40
D613, 614	Diode	1T22
D615, 616	Diode	1T40
D617 ~ 621	Diode	SIB01-02
D622, 623	Diode	1T40
D624	Diode	SIB01-02
D701 ~ 705	Diode	SIB01-02
D801 ~ 804	Diode	SIB01-02
D805	Diode	MZ-08
D901	Diode	SIB01-02
D941 ~ 943	Diode	SIB01-02

Ref. No. Part No. Description

COILS

L301, 401	1-409-130-00	2 mH, variable inductor
L501, 502	1-407-195-XX	1 mH, microinductor
L503, 504	1-407-239-00	3.3 mH, variable inductor
L505 ~ 508	1-407-284-00	1 mH, variable inductor
L951	1-407-213-XX	1.5 mH, microinductor
L952	1-407-196-XX	1.2 mH, microinductor
L953, 954	1-407-198-XX	2.2 mH, microinductor
L955	1-407-213-XX	1.5 mH, microinductor
L956	1-407-193-XX	1.2 mH, microinductor
L957, 958	1-407-198-XX	2.2 mH, microinductor

TRANSFORMERS

T301, 401	1-427-299-00	Output
T501	1-433-174-00	Bias Osc
T901	1-442-332-00	Power (USA, Canada Model)
T901	1-442-349-00	Power (PX Model)

CAPACITORS

All capacitors are in μF unless otherwise indicated.
(p = $\mu\mu$, elect = electrolytic)

C101, 201	1-121-398-11	10	25 V	elect
C102, 202				
C103, 203	1-121-413-11	100	6.3 V	elect
C104, 204	1-121-416-11	100	2.5 V	elect
C105, 205	1-121-398-11	10	25 V	elect
C106, 206				
C107, 207	1-121-416-11	100	25 V	elect
C108, 208				
C109, 209	1-121-398-11	10	25 V	elect
C110, 210	1-121-413-11	100	6.3 V	elect
C111, 211	1-105-669-12	0.0047	50 V	mylar
C112, 212	1-121-398-11	10	25 V	elect
C113, 213	1-121-726-11	0.47	50 V	elect
C114, 214	1-121-398-11	10	25 V	elect
C115, 215				
C116, 216	1-121-416-11	100	25 V	elect
C301, 401	1-121-416-11	100	25 V	elect
C302, 402	1-131-191-11	47	6.3 V	solid tantalum
C303, 403	1-105-661-12	0.001	50 V	mylar
C304, 404	1-107-135-11	150 p	50 V	silvered mica
C305, 405	1-123-139-11	100	16 V	elect

<u>Ref. No.</u>	<u>Part No.</u>	<u>Description</u>		
C306, 406	1-107-123-11	47 p	50 V	silvered mica
C307, 407	1-121-398-11	10	25 V	elect
C308, 408	1-121-420-11	220	10 V	elect
C309, 409	1-105-678-12	0.027	50 V	mylar
C310, 410	1-105-665-12	0.0022	50 V	mylar
C311, 411	1-121-416-11	100	25 V	elect
C312, 412	1-121-402-11	33	10 V	elect
C313, 413	1-121-410-11	47	25 V	elect
C314, 414	1-121-398-11	10	25 V	elect
C315, 415	1-105-661-12	0.001	50 V	mylar
C316, 416	1-121-479-11	22	16 V	elect
C317, 417	1-107-109-11	12 p	50 V	silvered mica
C318, 418	1-121-413-11	100	6.3 V	elect
C319, 419	1-107-244-11	470 p	50 V	silvered mica
C320, 420 C321, 421	1-121-398-11	10	25 V	elect
C322, 422	1-121-392-11	3.3	25 V	elect
C501, 502	1-105-665-12	0.0022	50 V	mylar
C503	1-121-410-11	47	25 V	elect
C504	1-121-395-11	4.7	25 V	elect
C505	1-105-681-12	0.047	50 V	mylar
C506	1-105-675-12	0.015	50 V	mylar
C507	1-107-183-11	390 p	500 V	silvered mica
C508	1-141-155-12	200 p ~ 600 p		trimmer
C509	1-107-187-11	560 p	500 V	silvered mica
C510, 511	1-107-179-11	270 p	500 V	silvered mica
C512 ~ 515	1-141-034-11	30 p ~ 200 p		trimmer
C516 ~ 519	1-107-036-11	68 p	500 V	silvered mica
C520	1-107-173-11	150 p	500 V	silvered mica
C601	1-121-392-11	3.3	52 V	elect
C602 ~ 604	1-121-726-11	0.47	50 V	elect
C605, 606	1-121-398-11	10	25 V	elect
C607	1-105-837-12	0.022	50 V	mylar
C608	1-121-395-11	4.7	25 V	elect
C609	1-121-411-11	47	50 V	elect
C610	1-105-841-12	0.047	50 V	mylar
C611	1-105-833-12	0.01	50 V	mylar
C612	1-121-726-11	0.47	50 V	elect
C613	1-105-839-12	0.033	50 V	mylar
C614	1-121-152-11	22	50 V	elect
C615	1-105-841-12	0.047	50 V	mylar
C616	1-105-845-12	0.1	50 V	mylar

<u>Ref. No.</u>	<u>Part No.</u>	<u>Description</u>		
C701	1-121-818-11	10	160 V	elect
C702	1-121-404-11	33	25 V	elect
C703	1-121-416-11	100	25 V	elect
C704 ~ 705	1-121-398-11	10	25 V	elect
C706	1-105-661-12	0.001	50 V	mylar
C707	1-131-239-11	6.8	35 V	solid tantalum
C708	1-105-683-12	0.068	50 V	mylar
C709	1-105-527-12	0.15	50 V	mylar
C710	1-105-675-12	0.015	50 V	mylar
C711	1-121-409-11	47	16 V	elect
C801, 802	1-121-810-11	470	50 V	elect
C803 ~ 805	1-121-388-11	1000	35 V	elect
C806	1-121-357-11	100	35 V	elect
C901 ~ 903	1-117-082-11	4	250 V	metalized paper
C941	1-129-774-11	0.068	200 V	polypropylene
C951, 952	1-121-409-11	47	16 V	elect
C953	1-105-519-12	0.033	50 V	mylar
C954	1-105-517-12	0.022	50 V	mylar
C955	1-105-522-12	0.056	50 V	mylar
C956, 957	1-105-519-12	0.033	50 V	mylar
C958	1-105-517-12	0.022	50 V	mylar
C959	1-105-522-12	0.056	50 V	mylar
C960	1-105-519-12	0.033	50 V	mylar
C991 ~ 998	1-101-885-11	56 p	50 V	ceramic

RESISTORS

All resistors are in Ω . $\frac{1}{4}W$, Regular type carbon and composition resistors are omitted.

Check schematic diagram for resistance values.

(k = 1000, M = 1000 k)

R125, 225 R126, 226	1-224-645-XX	22 k		adjustable
R134, 234	1-206-483-11	68	2 W	metal oxide
R313, 413 R314, 414	1-224-251-XX	4.7 k		adjustable
R315, 415 R316, 416	1-224-253-XX	22 k		adjustable
R333, 433	1-224-250-XX	2.2 k		adjustable
R701	1-206-652-11	330	2 W	metal oxide
R718	1-224-645-XX	10 k		adjustable
R719	1-224-646-XX	22 k		adjustable

<u>Ref. No.</u>	<u>Part No.</u>	<u>Description</u>	
R801	1-206-447-00	2.2	metal oxide
R806	1-224-644-XX	4.7 k	adjustable
R901	1-223-072-00	1.5 k	10 W adjustable, wirewound
R902	1-223-070-00	82	15 W adjustable, wirewound
R941	1-217-303-00	27	5 W metal oxide
R995, 996	1-224-447-00	20 k (A) variable, MIC	
R997, 998	1-224-449-00	20 k (A) variable, LINE	
R999, 1000	1-224-448-00	10 k (B) variable, PB LEVEL	

SWITCHES

S301, 501	1-514-813-XX	Slide, direction; forward/reverse	
S502, 503	1-514-813-XX	Slide, record/playback	
S701	1-514-803-00	Slide, TAPE SPEED	
S901	1-514-057-XX	Micro, fast forward	
S902	1-514-057-XX	Micro, forward	
S903	1-514-057-XX	Micro, stop	
S904	1-514-057-XX	Micro, reverse	
S905	1-514-057-XX	Micro, rewind	
S906	1-516-028-XX	Micro, shut off	
S907	1-516-028-XX	Micro, PAUSE	
S908	1-516-181-00	Push, POWER	
S911	1-514-323-00	Slide, AUTO REV	
S951	1-514-861-XX	Slide, TAPE SPEED	
S952	1-516-778-XX	Slide, BIAS (TAPE SELECT)	
S953	1-514-861-XX	Slide, EQ (TAPE SELECT)	
S971, 972	1-516-366-00	Lever Slide, MONITOR	

JACKS

J951, 952	1-507-349-21	2 P Phono, LINE IN	
J953, 954	1-507-476-XX	MICROPHONE	
J955, 956	1-507-378-XX	2 P Phono, LINE OUT	
J957	1-507-476-XX	Binaural, HEADPHONE	
J958	1-509-359-00	Connector, REC/PB (PX Model)	
CNP901	1-509-062-31	Connector, POWER SUPPLY	
CNP902	1-526-528-51	Connector, AC OUTLET	
CNP903	1-509-427-XX	Socket, voltage selector (PX Model)	

HEADS

H959 ~ 962	8-825-547-00	Erase, EF18-2902A2	
H951 ~ 954	8-825-534-00	Playback, PF140-4202	
H955 ~ 958	8-825-511-00	Record, RF140-2902	

<u>Ref. No.</u>	<u>Part No.</u>	<u>Description</u>
-----------------	-----------------	--------------------

MOTORS

M901	8-836-214-01	Capstan, UC-214G
M902, 903	8-836-624-09	Reel, UC-624K1

SOLENOIDS

PM901	1-454-130-00	Brake
PM902	1-454-128-00	Pinch Roller
PM903	1-454-131-00	Shifter
PM904	1-454-129-00	Reverse

MISCELLANEOUS

CP601 ~ 613	1-231-057-31	Encapsulated Component, 0.033 μ F + 120 Ω , 500 V
CP901, 941	1-101-534-31	Encapsulated Component, 0.1 μ F + 120 Ω , 500 V
F901	1-532-338-00	Fuse, 2 A (USA, Canada Model)
F901	1-532-363-XX	Fuse, 2.5 A (PX Model)
FG901		Included in Capstan Motor (M901)
FG902		Included in FG Ring Ass'y (X-3537-619-0)
ME951, 952	1-520-189-00	Meter, VU
PL901, 902	1-518-134-XX	Lamp, direction indicator
PL951, 952		Included in Meter (M951, 952)
PL953, 954	1-518-134-XX	Lamp, record indicator
RY601 ~ 604	1-515-127-00	Relay
	1-533-048-XX	Holder, fuse
	1-536-393-00	Terminal Strip, L1
	1-536-395-00	Terminal Strip, 1L1
	1-536-401-XX	Terminal Strip, 2L2

ACCESSORIES

<u>Part No.</u>	<u>Description</u>
X-2440-015-1	Reel Ass'y, R-7ES (PX Model)
X-3518-102-1	Reel Ass'y, R-7ES (USA and Canada Model)
X-3701-018-2	Stick Ass'y, head cleaning (Canada and PX Model)
1-534-049-31	Cord, connection; RK-74 (USA and Canada Model)
1-534-049-51	Cord, connection; RK-74 (PX Model)
1-534-099-XX	Cord, power (PX Model)
1-534-262-16	Cord, power (USA Model)
1-534-375-12	Cord, power (Canada Model)
3-140-949-03	Sheet, sensing
3-401-193-02	Tape, cotton (USA Model)
3-780-423-11	Manual, instruction (Canada Model)
3-780-423-21	Manual, instruction (USA Model)
3-780-423-61	Manual, instruction (PX Model)

SECTION 7 HARDWARE

<u>Part No.</u>	<u>Description</u>
SCREWS	
All screws are Phillips type (cross recess type) unless otherwise indicated. (-): slotted head.	
7-621-255-25	P 2 x 4
7-621-255-35	P 2 x 5
7-621-559-32	K 2.6 x 5
7-621-659-51	RK 3 x 8
7-621-712-38	SC 2.6 x 4, w/hexagon socket
7-621-712-51	(-) SC 2.6 x 6
7-628-253-95	PS 2.6 x 4
7-628-254-05	PS 2.6 x 5
7-628-254-15	PS 2.6 x 6
7-628-254-25	PS 2.6 x 8
7-628-254-95	PS 2.6 x 14
7-682-146-01	P 3 x 5
7-682-150-01	P 3 x 12
7-682-347-15	RK 3 x 6
7-682-547-01	B 3 x 6
7-682-548-01	B 3 x 8
7-682-565-01	B 4 x 16
7-682-624-01	PS 2 x 4
7-682-645-01	PS 3 x 4
7-682-646-01	PS 3 x 5
7-682-647-01	PS 3 x 6
7-682-648-01	PS 3 x 4
7-682-649-01	PS 3 x 10
7-682-660-01	PS 4 x 6

<u>Part No.</u>	<u>Description</u>
7-682-661-01	PS 4 x 8
	PS 4 x 22
7-682-947-01	PSW 3 x 6
7-682-948-01	PSW 3 x 8
7-682-961-01	PSW 4 x 8
7-682-963-01	PSW 4 x 12
7-683-140-00	SC 3 x 6, w/hexagon socket
7-683-237-31	SC 3 x 3, w/hexagon socket
7-683-240-31	(-) SC 3 x 3

WASHERS

7-623-105-12	2
7-623-107-12	2.6
7-623-108-12	3
7-623-110-12	4
7-623-112-12	5
7-623-205-22	.2, spring
7-623-208-22	.3, spring
7-623-210-21	4, spring

RETAINING RINGS

7-623-508-01	Lug 3
7-624-104-01	E 2
7-624-106-01	E 3
7-624-108-01	E 4
7-624-109-01	E 5
7-624-118-11	E 2.5

— Hardware Nomenclature —

